

DENON / PCM

digital recordings
GENERAL CATALOGUE

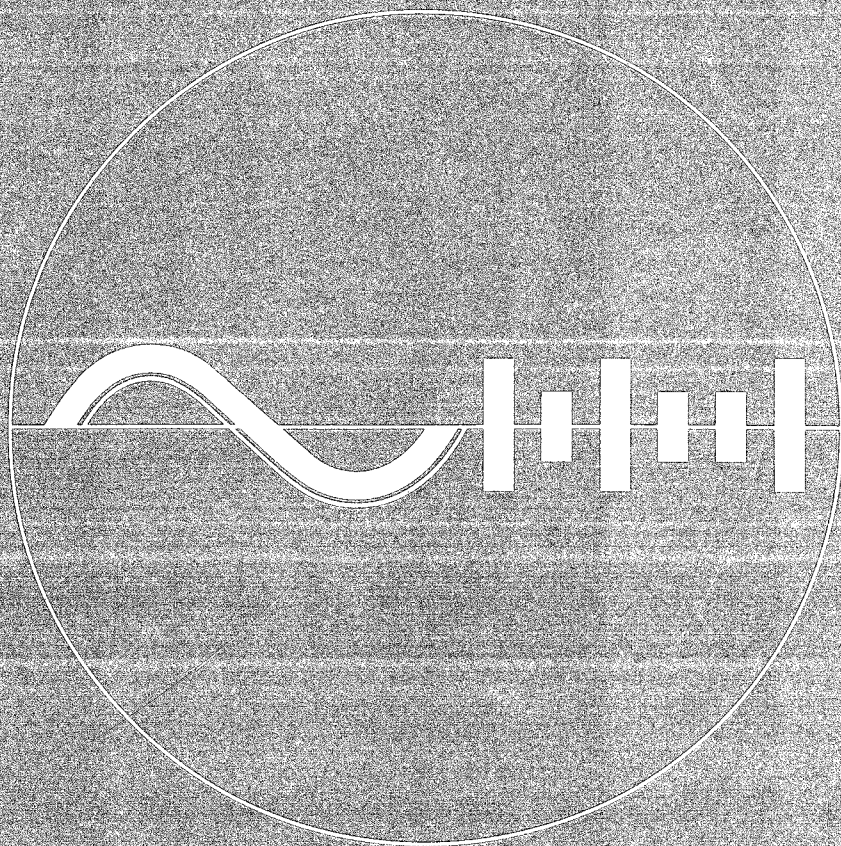

DENON PCM
RECORDING

NIPPON COLUMBIA CO. LTD. JAPAN

1980 / 81

DENON/PCM [digital recordings]
GENERAL CATALOGUE

— CONTENTS —

RECORD No.	DESCRIPTION	Page
0X-7000	CLASSICAL	1
0B-7000		28
0Q-7000		29
YX-7500	JAZZ	30
YX-7200	POPULAR	38
SX-7000		39
WP-7000	JAPANESE TRADITIONAL	41
WX-7000		42
ZX-7000	OTHERS	45
GX-7000		45
ST-6000	SPECIAL ISSUED ALBUM	46
OW-7000	AUDIO TECHNICAL RECORD (45 rpm)	47
XG-7000	AUDIO TECHNICAL RECORD (33 rpm Regular Stereo recordings)	48
About DENON PCM [digital recording] System		50
NUMERICAL LIST FOR INVENTORY & ORDER		54







NOTICE:

SELECTIONS INDICATED BY AN ASTERISK. (*)

* are not available for FRANCE, BENELUX & SWITZERLAND.

** are not available for ALL EUROPEAN COUNTRIES.

*** are not available for any countries except for AUSTRALIA & SOUTH EAST ASIA COUNTRIES.







<p>OX-7002</p>		<p>JAN PANENKA PLAYS SCHUMANN CARNAVAL, OP.9 KINDERSZENEN, OP.15</p> <p>Recorded on Mar. 20 & 22, 1974 in Tokyo</p>	<p>Jan PANENKA, piano</p>
<p>OX-7004</p>		<p>MUSSORGSKY : PICTURES AT AN EXHIBITION RACHMANINOV : 3 PRELUDES OP. 23-2, 4 & 5</p> <p>Recorded on Nov. 14/15, 1973 in Chiba Japan</p>	<p>Takahiro SONODA, piano (Baldwin SD 10)</p>
<p>OX-7005</p>		<p>VIVALDI : SIX SONATAS FOR FLUTE AND HARPSICHORD, OP.13</p> <p>No. 1 in C major No. 3 in G major No. 2 in C major No. 4 in A major No. 5 in C major No. 6 in G major</p> <p>Recorded on June 17 & 18, 1974 in Tokyo</p>	<p>Maxence LARRIEU, flute Robert VEYRON-LACROIX, harpsichord and realisation</p>
<p>OX-7006</p>		<p>FOUR TRIO SONATAS FOR TWO FLUTES AND HARPSICHORD C. Ph. E. BACH: TRIO SONATA IN D MINOR TELEMANN: TRIO SONATA IN E MINOR C. Ph. E. BACH: TRIO SONATA IN E MAJOR J. S. BACH: TRIO SONATA IN G MAJOR</p>	<p>Jean-Pierre RAMPAL and Maxence LARRIEU, flute Motoko NABESHIMA, harpsichord</p>
<p>OX-7007*</p>		<p>TELEMANN : TWELVE FANTASIES FOR FLUTE SOLO</p> <p>No. 1 in A major No. 2 in A minor No. 3 in B flat minor No. 4 in B flat major No. 5 in C major No. 6 in D minor No. 7 in D major No. 8 in E minor No. 9 in E major No.10 in F sharp minor No.11 in G major No.12 in G major</p> <p>Recorded on Oct. 30, 1972 in Tokyo</p>	<p>Jean-Pierre RAMPAL, flute</p>
<p>OX-7008</p>		<p>MOZART: STRING QUARTETS NO.17 IN B FLAT MAJOR, KV 458 "HUNTING" NO.15 IN D MINOR, KV 421</p> <p>Recorded on Apr. 24→26, 1972 in Tokyo *Prize of "Record Academy" Tokyo</p>	<p>SMETANA QUARTET</p>
<p>OX-7009</p>		<p>SCHUBERT : STRING QUARTET IN D MINOR "DEATH AND THE MAIDEN"</p> <p>TCHAIKOVSKY : ANDANTE CANTABILE FROM STRING QUARTET NO.1</p> <p>Recorded on Oct. 28, 1973 in Tokyo</p>	<p>PRAGUE QUARTET</p>







OX-7011		<p>RUZICKOVA PLAYS FAVORITE HARPSICHORD MUSIC HANDEL: THE HARMONIOUS BLACKSMITH GRAFT: GROUND IN C MINOR BYRD: THE PIPES AND DRUMS BYRD: LA VOLTA RAMEAU: LE TAMBOURIN RAMEAU: MUSETTE EN RONDEAU F. COUPERIN: LES FASTES DE LA GRANDE ET ANCIENNE MENESTRANDISE D'AQUIN: LE COUCOU D. SCARLATTI: SONATA IN G MINOR FRESCOBALDI: TOCCATA DETTA "LA FRESCOBALDA" MYSLIVECEK: SONATA IN A MAJOR --ALLEGRO BARTOK: THE STORY OF THE LITTLE FLY/BAGPIPE/BULGARIAN DANCE Recorded on Nov. 19 1972 in Tokyo</p>	Zuzana RUZICKOVA , harpsichord (Ammer)
OX-7012		<p>VLADO PERLEMUTER PLAYS FRENCH MUSIC RAVEL: SONATINE DEBUSSY: POUR LE PIANO DEBUSSY: IMAGE, Book-1 FAURE: THEME AND VARIATIONS Recorded on Dec. 12/13, 1972 in Tokyo</p>	Vlado PERLEMUTER , piano
OX-7013		<p>HISTORICAL GUITAR COLLECTION OF CASA DE MUSICA Roncalli: PASSACAGLIA Sanz: PAVANE Visee: SUITE IN D MINOR Carulli: PRELUDE OP.114 Aguado: VALSE OP.1-7 Sor: ETUDE IN B MINOR, OP.35-22 Giuliani: TEMA E VARIAZIONI, OP.105 K. Merts: LE GONDLIER Paganini: ROMANZE Tarrega: MAZURKA "SUENO" Tarrega: RECUERDOS DE LA ALHAMBRA Llobet: EL MESTRE Villa-Lobos: PRELUDE NO.3 Tansman: "ENTREE" from SUITE "IN MODO POLONICO" Tansman: "OBEREK" from SUITE "IN MODO POLONICO"</p>	<p>FRANCISKO PEREZ (1763 Cadiz) played by Mitsuhiro HAMADA RENE FRANÇOIS LACOTE (1828 Paris) played by Hideo SHINMA GEORGE LOUIS PANORMO 1 (1932 London) JOHANN GEORG STAUFFER (1840 Vienna) GROBERT (1810 Paris) played by Masaru KOYAMA ANTONIO DE TORRES JURADO (1852 Aleria and 1863 Sevilla) DIEGO GRACIA (NUNEZ) (1964 Buenos Aires) played by Mikio HOSHIDO</p>
OX-7014		<p>TOSHIHARU ICHIKAWA "SYMPHONY"—BASED ON JAPANESE MODE Recorded on Apr. 20 & 21, 1977 in Prague</p>	Zdenek KOSLER , conducting CZECH PHILHARMONIC ORCHESTRA
OX-7021***		<p>BACH: MUSICAL OFFERING BWV1079 Recorded on Dec. 2 & 3, 1974 in Paris</p>	ORCHESTRE DE CHAMBRE JEAN-FRANÇOIS PAILLARD
OX-7022*		<p>MOZART: SYMPHONIE CONCERTANTE FOR VIOLIN, VIOLA AND ORCHESTRA, KV364 CONCERTONE IN C MAJOR FOR TWO VIOLINS AND ORCHESTRA, KV190 Recorded on Nov., 1974 in Paris</p>	ORCHESTRE DE CHAMBRE JEAN-FRANÇOIS PAILLARD Gerard JARRY , violin Jean-Jacques KANTOROW , violin Serge COLLOT , viola









<p>OX-7023</p>		<p>BACH : ORGAN CHORALS FOR THE LITURGICAL CHURCH YEAR Recorded on Dec. 12→19, 1974 in Stuttgart</p>	<p>Helmuth RILLING, organ at Gedachtniskirche in Stuttgart</p>
<p>OX-7024</p>		<p>ANNEROSE SCHMIDT PLAYS CHOPIN-1 BALLADES NO.1 & NO.3 ETUDES OP.10-9, 10 & 12 "REVOLUTION" POLONAISE, OP.55 "HEROIC" MAZURKAS, OP.33-4, 63-3 & 67-4 Recorded on Nov. 16→18, 1974 in Tokyo</p>	<p>Annerose SCHMIDT, piano</p>
<p>OX-7025*</p>		<p>TWO CONCERTOS FOR VIOLIN MOZART: VIOLIN CONCERTOS NO.1 IN B-flat MAJOR, KV207 NO.2 IN D MAJOR, KV211 Recorded on Nov. 25, 26 & 28, 1974 in Paris</p>	<p>Gerard JARRY, violin ORCHESTRE DE CHAMBRE JEAN-FRANÇOIS PAILLARD</p>
<p>OX-7026</p>		<p>TOURNEE EN EUROPE BAROQUE TELEMANN: QUARTET IN G MAJOR L. COUPERIN: PIECE DE CLAVECIN VIVALDI: SONATA IN A MINOR, FOR FLUTE, BASSOON and HARPSICHORD, F.XV NO.1 F. COUPERIN: SONATA IN B-flat MAJOR "LA STEINQUERQUE" BARBASTRE: LA D'HERICOURT POUR CLAVECIN BACH: TRIO SONATA IN G MAJOR BWV1038 Recorded on June 23/24, 1974 in Tokyo</p>	<p>ENSEMBLE BAROQUE DE PARIS</p>
<p>OX-7027</p>		<p>BACH: THE MASTERWORKS FOR ORGAN TOCCATA AND FUGUE BWV565 PASACAGLIA BWV582 FANTASIE AND FUGUE BWV542 PRELUDE AND FUGUE BWV544 FUGUE BWV578 Recorded on Dec. 12→19, 1974 in Stuttgart</p>	<p>Helmuth RILLING, organ at Gedachtniskirche in Stuttgart</p>
<p>OX-7028</p>		<p>BACH CONCERT RICERCARE A 6 from Musical Offering BWV1079 BRANDENBURG CONCERTO NO.3 PRELUDE AND FUGUE, BWV541 THREE CONTRAPUNCTS from The Art of The Fugue BWV1080 Recorded on Sept. 18 & 19, 1974 in Kawaguchi, Japan</p>	<p>VASSIL KASANDJIEV conducting SOFIA CHAMBER ORCHESTRA</p>
<p>OX-7029</p>		<p>RANKI PLAYS LISZT APRES UNE LECTURE DU DANTE, fantasia quasi sonata, G161 MEPHISTO WALTZ NO.1 G514 SONATA IN B MINOR, G178 Recorded on May 4/5, 1975 in Tokyo *Grand Prix du Disque Académie Liszt Prize, Budapest</p>	<p>Dezső RANKI, piano</p>
<p>OX-7030</p>		<p>SONATAS AND DIVERTIMENTOS BOIMORTIER: SONATA IN E MINOR HÄNDEL: SONATA IN G MINOR TELEMANN: SONATA IN A-flat MAJOR MOZART: DIVERTIMENTO KV252 MOZART: DIVERTIMENTO KV240 Recorded on June 2/3, 1974 in Tokyo</p>	<p>Pierre PIERLOT, oboe Paul HONGNE, bassoon Robert VEYRON-LACROIX, harpsichord</p>



OX-7031		<p>MUSIC TODAY FOR OBOE AND STRINGS VERESS: PASSACAGLIA CONCERTANTE PENDERECKI: CAPRICCIO YUN: PIRI for Oboe Solo DENISOW: SOLO for Oboe HOLLIGER: STUDIE ÜBER MEHRKLÄNGE · LIED</p> <p>Recorded on Nov. 20, 1974 in Tokyo</p>	<p>Heinz HOLLIGER, oboe CAMERATA BERN</p>
OX-7032		<p>DEBUSSY: MUSIC FOR PIANO IMAGES, BOOK 1 and BOOK 2 ESTAMPES, L'ILE JOYEUSE</p> <p>Recorded on Apr. 2/3, 1975 in Tokyo</p>	<p>Yuji TAKAHASHI, piano</p>
OX-7033		<p>BACH: THREE KEYBOARD CONCERTOS NO.1 IN D MINOR, BWV1052 NO.5 IN F MINOR, BWV1056 NO.4 IN A MAJOR, BWV1055</p> <p>Recorded on July 5/6, 1973 in Kawaguchi, Japan</p>	<p>Yuji TAKAHASHI, piano (Steinway) and electric piano TOKYO BACH PLAYERS</p>
OX-7034		<p>MOZART: STRING QUARTETS NO.14 IN G MAJOR, KV387 "SPRING" NO.16 IN E-flat MAJOR, KV428</p> <p>Recorded on June 10→18, 1975 in Czechoslovakia</p>	<p>SMETANA QUARTET</p>
OX-7035**		<p>BETHOVEN: TRIO IN B-flat MAJOR FOR PIANO, VIOLIN AND CELLO OP.97 "ARCHDUKE"</p> <p>Recorded on June 14/15, 1975 in Czechoslovakia</p>	<p>SUK TRIO</p>
OX-7036		<p>RANKI PLAYS SCHUBERT PIANO SONATA D.960 IMPROMPTUS OP.90-2 and 3</p> <p>Recorded on Apr. 23/24, 1975 in Tokyo</p>	<p>Dezső RANKI, piano</p>
OX-7037-8** (2 records set)		<p>HANDEL: EIGHT SONATAS FOR VIOLIN AND HARPSICHORD SONATAS OP.1, NO.3, 10, 12-15 SONATAS OP.1, NO.6, 11</p> <p>Recorded on June 30 & July 1/2, 1975 in France</p>	<p>Josef SUK, violin Zuzana RUZICKOVA, harpsichord</p>
OX-7039		<p>MOZART: STRING QUARTETS NO.18 IN A MAJOR, KV464 NO.19 IN A MAJOR, "DISSONANT" KV465</p> <p>Recorded June 12→23, 1975 in Czechoslovakia</p>	<p>SMETANA QUARTET</p>
OX-7040		<p>VIRTUOSOS FOR STRINGS PERCELL: SUITE IN E MINOR GLUCK: SINFONIA IN G MAJOR VIVALDI: SINFONIA NO.3 IN G MAJOR HAYDN: DIVERTIMENTO Hob. II:6</p> <p>Recorded on Sept. 18 & 19, 1974 in Kawaguchi, Japan</p>	<p>Vassil KASANDJIEV conducting SOFIA CHAMBER ORCHESTRA</p>





<p>OX-7041</p>		<p>STARKER PLAYS FAVORITE CELLO MUSIC W.F. BACH: GRAVE HAYDN: DIVERTIMENTO IN D MAJOR SAINT-SAENS: THE SWAN SCHUBERT: MOMENT MUSICAL BLOCH: PRAYER POPPER: TARANTELLA J.S. BACH: ARIOSO FRESCOBALDI: TOCCATA SCHUMANN: ABENDLIED WEBER: ADAGIO AND RONDO SCHUMANN: TRÄUMEREI BARTOK: RUMANIAN FOLK DANCES</p> <p>Recorded on Mar. 16/17, 1975 in Tokyo</p>	<p>Janos STARKER, cello Shuku IWASAKI, piano</p>
<p>OX-7042</p>		<p>SCHUBERT: STRING QUARTETS NO.13 "ROSAMUNDE" D.804 NO.12 "QUARTETTSATZ" D.703</p> <p>Recorded on Oct. 1/2, 1975 in Tokyo</p>	<p>PRAGUE QUARTET</p>
<p>OX-7043**</p>		<p>SCHUBERT: TRIO IN B-flat MAJOR FOR PIANO, VIOLIN AND CELLO OP.99 NOTTURNO IN E-flat MAJOR FOR PIANO, VIOLIN AND CELLO, OP.148</p> <p>Recorded on June 19/20, 1975 in Czechoslovakia</p>	<p>SUK TRIO</p>
<p>OX-7044</p>		<p>KOCSIS PLAYS BARTOK ALEGRO BARBARO THREE RONDS ON FOLK TUNES THREE HUNGARIAN FOLK TUNES SUITE OP.14/SONATA (1926) RUMANIAN FOLK DANCES HUNGARIAN PEASANT SONGS</p> <p>Recorded on Oct. 23/24, 1975 in Tokyo</p>	<p>Zoltan KOCSIS, piano</p>
<p>OX-7045-7 (3 records boxed)</p>		<p>BACH: THE COMPLETE SUITES FOR CELLO UNACCOMPANIED SUITE NO.1, BWV1007—NO.6, BWV1012</p> <p>Recorded in Kawaguchi, Japan</p>	<p>Ken YASUDA, cello</p>
<p>OX-7048</p>		<p>THE BACH ORGAN CONCERT AT SOROE CHURCH PRELUDE AND FUGUE BWV552 FUGUE BWV578 CHORALS BWV147/754/668 CONCERTO BWV594</p> <p>Recorded on Jan. 17/18, 1976 in Denmark</p>	<p>Knud VAD, organ Marcussen</p>
<p>OX-7049**</p>		<p>SMETANA: STRING QUARTETS NO.1 IN E MINOR "FROM MY LIFE" NO.2 IN D MINOR</p> <p>*Prize "Record Academy" Tokyo Recorded on Feb. 12→16, 1976 in Prague</p>	<p>SMETANA QUARTET</p>
<p>OX-7051*</p>		<p>MOZART: THE COMPLETE PIANO SONATAS-1 SONATA NO.1, KV279 NO.2, KV280 NO.3, KV281</p> <p>*Grand Prix du Disque Académie du Disque Français, Paris *Prix Edison de la Critique Hollandaise du Disque, Amsterdam</p>	<p>Maria Joao PIRES, piano</p>









OX-7052*		<p>MOZART : THE COMPLETE PIANO SONATAS-2 SONATA NO.4, KV282 NO.5, KV283 NO.6, KV284</p> <p>*Grand Prix du Disque Académie du Disque Français, Paris *Prix Edison de la Critique Hollandaise du Disque, Amsterdam</p>	Maria Joao PIRES, piano
OX-7053*		<p>MOZART : THE COMPLETE PIANO SONATAS-3 SONATA NO.7, KV309 NO.9, KV311</p> <p>*Grand Prix du Disque Académie du Disque Français, Paris *Prix Edison de la Critique Hollandaise du Disque, Amsterdam</p>	Maria Joao PIRES, piano
OX-7054*		<p>MOZART : THE COMPLETE PIANO SONATAS-4 FANTASY IN D MINOR KV397 SONATA NO.8, KV310 NO.11, KV331</p> <p>*Grand Prix du Disque Académie du Disque Français, Paris *Prix Edison de la Critique Hollandaise du Disque, Amsterdam</p>	Maria Joao PIRES, piano
OX-7055*		<p>MOZART : THE COMPLETE PIANO SONATAS-5 SONATA NO.10, KV330 NO.12, KV332 RONDO IN D MINOR, KV511</p> <p>*Grand Prix du Disque Académie du Disque Français, Paris *Prix Edison de la Critique Hollandaise du Disque, Amsterdam</p>	Maria Joao PIRES, piano
OX-7056*		<p>MOZART : THE COMPLETE PIANO SONATAS-6 SONATA NO.13, KV333 NO.15, KV533</p> <p>*Grand Prix du Disque Académie du Disque Français Paris *Prix Edison de la Critique Hollandaise du Disque, Amsterdam</p>	Maria Joao PIRES, piano
OX-7057*		<p>MOZART : THE COMPLETE PIANO SONATAS-7 SONATA NO.16, KV545 FANTASY IN C MINOR, KV475 SONATA NO.14, KV457</p> <p>*Grand Prix du Disque Académie du Disque Français, Paris *Prix Edison de la Critique Hollandaise du Disque, Amsterdam</p>	Maria Joao PIRES, piano

<p>OX-7058*</p>		<p>MOZART: THE COMPLETE PIANO SONATAS-8 SONATA NO.17, KV570 ROUND IN D MAJOR, KV485 SONATA NO.18, KV576</p> <p>*Grand Prix du Disque Académie du Disque Français, Paris *Prix Edison de la Critique Hollandaise du Disque, Amsterdam</p>	<p>Maria Joao PIRES, piano</p>
<p>OX-7059</p>		<p>JOHN CAGE: SONATAS AND INTERLUDES FOR PREPARED PIANO</p> <p>Recorded on Dec. 1, 1975 in Tokyo *Prize of "Record Academy" Tokyo</p>	<p>Yuji TAKAHASHI prepared piano</p>
<p>OX-7060</p>		<p>VIRTUOSO !! BACH: FANTASIE AND FUGUE, BWV542 BACH: AIR from Orchestral Suite No.3 BOCCHERINI: MENUETTO SCHUBERT: MOMENT MUSICAL PURCELL: SUITE " ABDELAZER " MUFFAT: OVERTURE HINDEMITH: 5 PIECES FOR STRINGS</p> <p>Record on Apr. 10 & 11, 1973 in Tokyo</p>	<p>Vassil KASANDJIEV conducting SOFIA CHAMBER ORCHESTRA</p>
<p>OX-7061</p>		<p>INVITATION TO THE BAROQUE MUSIC ALBINONI: ADAGIO IN G MINOR BACH: AIR from Orchestral Suite No.3 PURCELL: CHACONNE IN G MINOR FOR 4 VOICE HANDEL: MENUETTO from "Herakles"/ ARIA from Concerto Grosso Op.6-12 SAMMARTINI: ANDANTE AMOROSO MARCELLO: ADAGIO BACH: LARGO PACHELBEL: CANON AND GIGUE</p> <p>Recorded on Jan. 13→15, 1976 in Copenhagen</p>	<p>Jorgen Ernst HANSEN conducting "SOCIETAS MUSICA" CHAMBER ORCHESTRA, COPENHAGEN</p>
<p>OX-7063</p>		<p>XENAKIS: EVRYALI/HERMA MESSIAEN: 4 ETUDES DE RYTHME</p> <p>Recorded on May 20/21, 1976 in Tokyo</p>	<p>Yuji TAKAHASHI, piano</p>
<p>OX-7064-5 (2 records set)</p>		<p>PURCELL: THE COMPLETE WORKS FOR HARPSICHORD SUITES NO.1—NO.8 THIRTEEN PIECES FROM "THE SECOND PART OF MUSIC'S HANDMAID" 1689 SIX PIECES FROM "A CHOICE COLLECTION OF LESSONS" PIECES FROM VARIOUS SOURCES PIECES OF DOUBTFUL AUTHENTICITY</p> <p>Recorded on May 26→29, 1975 in Tokyo</p>	<p>Zuzana RUZICKOVA, harpsichord (Thomas' Copy and Neupert)</p>
<p>OX-7066**</p>		<p>JANACEK: STRING QUARTETS NO.1 "KREUTZER SONATA" NO.2 "INTIMATE PAGES"</p> <p>Recor on Feb. 18→20 & June 1→3, 1976 in Prague</p>	<p>SMETANA QUARTET</p>









<p>OX-7067**</p>		<p>TCHAIKOVSKY : TRIO IN A MINOR FOR PIANO, VIOLIN AND CELLO, OP.50 " TO THE MEMORY OF A GREAT ARTIST "</p> <p>Recorded on June 23/24, 1976 in Tokyo</p>	<p>SUK TRIO</p>
<p>OX-7068</p>		<p>TELEMANN : SUITE AND CONCERTI-1 OVERTURE IN G MAJOR FOR STRINGS AND BASSO CONTINUO " LA PUTAN " CONCERTO IN B-flat MAJOR FOR TREBLE RECORDER, OBOE, STRINGS AND BASSO CONTINUO CONCERTO IN F MINOR FOR OBOE AND STRINGS CONCERTO IN G MAJOR FOR VIOLA AND STRINGS</p> <p>Recorded on Jan. 18/19, 1976 in Copenhagen</p>	<p>Jorgen Ernst HANSEN conducting " SOCIETAS MUSICA " CHAMBER ORCHESTRA, COPENHAGEN</p>
<p>OX-7069</p>		<p>TRUMPET AND ORGAN TELEMANN : 12 HEROIC MARCHES HANDEL : SUITE IN D MAJOR CORELLI : SONATA IN E MINOR ALBINONI : CONCERT IN F MAJOR</p> <p>Recorded on July 20 & 25, 1976 in Denmark</p>	<p>Bernard GABEL, trumpet Knud VAD, organ</p>
<p>OX-7070</p>		<p>STOIKA MILANOVA VIOLIN RECITAL PROKOFIEV : SONATA NO.2 IN D MAJOR, OP.94 DEBUSSY : SONATA RAVEL : TZIGANE</p> <p>Recorded on Mar. 20, 1976 in Tokyo</p>	<p>Stoika MILANOVA, violin Dora MILANOVA, piano</p>
<p>OX-7071</p>		<p>SATIE : MUSIC FOR PIANO GYMNOPEDIES I, II, III GNOSSIENNES I, II, III, PRELUDE DE LA PORTE HÉRÔIQUE DU CIER JE TE VEUX PIECES FROIDES NOCTURNES I, II, III, IV, V RAG-TIME PARADE</p> <p>Recorded on Jan. 28/29, 1976 in Tokyo</p>	<p>Yuji TAKAHASHI, piano stainway</p>
<p>OX-7072</p>		<p>MOUSSORGSKY : PICTURES AT AN EXHIBITION RAVEL : PAVANE POUR UNE INFANTE DÉFUNTE</p> <p>Recorded on Dec. 9 & 10, 1972</p>	<p>Louis FREMAUX, conducting THE TOKYO METROPOLITAN SYMPHONY ORCHESTRA</p>
<p>OX-7073</p>		<p>HAYDN : STRING QUARTET IN D MAJOR, OP.64-5 " LARK "</p> <p>SCHUMANN : QUINTET IN E-flat MAJOR FOR PIANO AND STRINGS</p> <p>Recorded on June 26, 1976 in Tokyo</p>	<p>BERLIN STRING QUARTET Kazuko NAGATOMI, piano</p>
<p>OX-7074</p>		<p>TELEMANN : SUITE AND CONCERTI-2 SUITE IN A MINOR FOR TREBLE RECORDER, STRINGS AND BASSO CONTINUO " LES PLAISIRS " CONCERTO IN D MAJOR FOR FLUTE, STRINGS AND BASSO CONTINUO CONCERTO IN A MINOR FOR VIOLIN, STRINGS AND BASSO CONTINUO</p> <p>Recorded on Jan. 20/21. 1976 in Copenhagen</p>	<p>Jorgen Ernst HANSEN, conducting " SOCIETAS MUSICA " CHAMBER ORCHESTRA, COPENHAGEN</p>









<p>OX-7075</p>		<p>JOHN O'CONNOR PLAYS BEETHOVEN SONATA NO.8 IN C MINOR, OP.13 "PATHETIQUE" SONATA NO.14 IN C-Sharp MINOR OP.27-2 "MOONLIGHT" SONATA NO.19 IN G MINOR, OP.49-1 SONATA NO.20 IN G MINOR, OP.49-2 Recorded May 30/31, 1976 in Tokyo</p>	<p>John O'CONNOR, piano</p>
<p>OX-7076</p>		<p>KODALY : SONATA FOR CELLO SOLO, OP.8 TCHEREPNINE : SUITE FOR CELLO SOLO (World Premiere Recording) Recorded on Feb. 4 & 6, 1975 in Kawaguchi, Japan</p>	<p>Ken YASUDA, cello</p>
<p>OX-7077**</p>		<p>BEETHOVEN : STRING QUARTETS NO.2 IN G MINOR OP.18-2 NO.4 IN C MINOR OP.18-4 Recorded on June 14 &18, 1976 in Prague</p>	<p>SMETANA QUARTET</p>
<p>OX-7078</p>		<p>DVORAK : SERENADE IN E MAJOR FOR STRING ORCHESTRA TCHAIKOVSKY : SERENADE IN C MAJOR FOR STRINGS Recorded on Mar. 30 & 31, 1976 in Tokyo</p>	<p>Vassil KASANDJIEV conducting SOFIA CHAMBER ORCHESTRA</p>
<p>OX-7079</p>		<p>GERARD JARRY PLAYS KLEISLER FAVORITES POLICHINELLE SICILIENNE ET RIGAUDON DANSE ESPAGNOLE DE " LA VIDA BREVE" HINDU-LIED AUS DER OPER " SADKO " LIEBESFREUD LIEBESLEID TANGO CAPRICE VIENNOIS, OP.2 ROMANZE, OP.4 TAMBOURIN CHINOIS, OP.3 DANSE ESPAGNOLE SCHÖN ROSMARIN Recorded on Sep. 16/17, 1976 in Tokyo</p>	<p>Gerald JARRY, violin Shuku IWASAKI, piano</p>
<p>OX-7080</p>		<p>BACH : THE GOLDBERG VARIATIONS BWV988 14 CANONS on the first 8 notes of the Aria ground from Goldberg Variations, BWV1087 (World Premiere Recording) Recorded on Oct. 19/20, 1976 in Tokyo</p>	<p>Yuji TAKAHASHI, piano and synthesizer Roland</p>
<p>OX-7081</p>		<p>MOZART : SONATAS FOR PIANO AND VIOLIN-1 SONATA IN B-flat MAJOR, KV 378 (317d) SONATA IN F MAJOR, KV 376 (374d) SONATA IN F MAJOR, KV377 (374e) Recorded on July 3 & 6, 1976 in France</p>	<p>Alain PLANES, piano Jean-Jacques KANTOROW, violio</p>
<p>OX-7082</p>		<p>C.P.E. BACH : FOUR SONATAS FOR FLUTE AND HARPSICHORD NO.1 IN D MAJOR, Wq 83 NO.2 IN E MAJOR, Wq 84 NO.3 IN G MAJOR, Wq 85 NO.4 IN G MAJOR, Wq 86 Recorded on Aug. 15→17, 1976 in Munich</p>	<p>Andras ADORJAN, flute Huguette DREYFUS, harpsichord</p>







OX-7083		DREYFUS PLAYS HARPSICHORD MUSIC BACH : ITALIAN CONCERTO IN F MAJOR, BWV971 CHROMATIC FANTASIA AND FUGUE IN D MINOR, BWV903 FANTASIA IN C MINOR, BWV906 PRELUDE AND FUGUE IN A MINOR, BWV895 Recorded on Jan. 3 & Aug. 14, 1976 in Munich	Huguette DREYFUS, harpsichord
OX-7084		CHOPIN : THE 14 WALTZES No. 1 in E flat major, Op.18 No. 2 in A flat major, Op.34, No.1 No. 3 in A minor, Op.34, No.2 No. 4 in F major, Op.34, No.3 No. 5 in A flat major, Op.42 No. 6 in D flat major, Op.64, No.1 No. 7 in C sharp minor, Op.64, No.2 No. 8 in A flat major, Op.64, No.3 No. 9 in A flat major, Op.69, No.1 No.10 in B minor, Op.69, No.2 No.11 in G flat major, Op.70, No.1 No.12 in F minor, Op.70, No.2 No.13 in D flat major, Op.70, No.3 No.14 in E major Op. posth Record on Sep. 24/25, 1976 in Tokyo	Arthur MOREIRA-LIMA, piano
OX-7085		FAURÉ : SONATAS FOR VIOLIN AND PIANO NO.1 IN A MAJOR, OP.13 NO.2 IN E MINOR, OP.108 BERCEUSE FOR VIOLIN AND PIANO Record on July 3 & 5, 1975 in France	Jean-Jacques KANTOROW, violin Alain PLANES, piano
OX-7086-7 (2 records set)		BACH : THE COMPLETE SONATAS FOR FLUTE SONATA IN B MINOR, BWV 1030 SONATA IN E-flat MAJOR, BWV 1031 SONATA IN A MAJOR, BWV1032 SONATA IN G MINOR, BWV1020 SONATA IN C MAJOR, BWV1033 SONATA IN E MINOR, BWV1034 SONATA IN E MAJOR, BWV1035 PARTITA IN A MINOR, BWV1013 Recorded on Dec. 27, 1975 & Jan. 2, 1976 in Munich	Andras ADORJAN, flute Huguette DREYFUS, harpsichord (Schütze) Joachim RABE, viola da gamba
OX-7088		JAPANESE FAVORITE MELODIES HAMABE NO UTA AKAI KUTSU YOIMACHIGUSA YURIKAGO NO UTA KONO MICHI TOORYANSE DEFUNE AKATOMBO NANATSU NO KO TSUKI NO SABAKU SOUSHUNFU YASHINOMI JOGASHIMA NO AME SHIKARARETE Recorded on Aug. 10/11, 1976 in Tokyo	Masaaki HAYAKAWA conducting THE VIVALDI ENSEMBLE, Tokyo
OX-7089**		MOZART: STRING QUINTETS NO.3 IN C MAJOR, KV515 NO.4 IN G MINOR, KV516 Recorded on July 7→10, 1976 in Prague *Prize of "Record Academy," Tokyo	SMETANA QUARTET Josef SUK, 1st viola

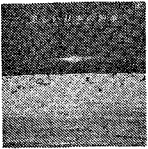

<p>OX-7090</p>		<p>MOZART: SONATAS FOR PIANO AND VIOLIN-2 SONATA IN E-flat MAJOR, KV380 SONATA IN A MAJOR, KV526 Recorded on July 7 & 10, 1975 in France</p>	<p>Alain PLANES piano Jean-Jacques KANTOROW, violin</p>
<p>OX-7091</p>		<p>BACH: INVENTIONS AND SINFONIAS BWV772a-801 Recorded on Jan. 8/9, 1977 in Tokyo</p>	<p>Yuji TAKAHASHI, piano</p>
<p>OX-7092</p>		<p>THE CELEBRATED MUSIC OF VERSAILLE COUPERIN: SONATA "ASTREE" MARAIS: SUITE EN TRIO NO.5 QUINTIN: SONATA IN E MINOR RAMEAU: CONCERT EN SEXTOUR NO.4 "PANTOMIME" Recorded on July 7→9, 1975 in France</p>	<p>QUATOUR INSTRUMENTAL DE PARIS</p>
<p>OX-7093</p>		<p>SCHUBERT: THREE SONATINES FOR PIANO AND VIOLIN SONATINE IN D MAJOR, OP.137-1, D384 SONATINE IN G MINOR, OP.137-3, D408 SONATINE IN A MINOR, OP.137-2, D385 Recorded on Sept. 7/8, 1976 in Tokyo</p>	<p>Gerard JARRY, violin Shuku IWASAKI, piano</p>
<p>OX-7094</p>		<p>BRAHMS: THE COMPLETE SONATAS FOR VIOLIN AND PIANO-1 SONATA IN G MAJOR, OP.78 SONATA IN A MAJOR, OP.100 Recorded on Dec. 15 & 19, 1975 in France</p>	<p>Jean-Jacques KANTOROW, violin Alain PLANES, piano</p>
<p>OX-7095</p>		<p>BRAHMS: THE COMPLETE SONATAS FOR VIOLIN AND PIANO-2 SONATA NO.3 IN D MINOR, OP.108 SONATA F.A.E. (Dietrich—Schumann— Brahms) Recorded on Dec. 20, 21, 1975 & July 1, 2, 1976</p>	<p>Jean-Jacques KANTOROW, violin Alain PLANES, piano</p>
<p>OX-7096</p>		<p>STEPHEN KATES PLAYS FAVORITE CELLO MUSIC FRANCOEUR: SONATA IN E MAJOR SAINT-SAENS: LE CYGNE KREISLER: LIEBESLEID LUKAS FOSS: CAPRICCIO J.S. BACH: PASTORALE SCHUBERT: INTRODUCTION, THEME AND VARIATIONS, OP.82-2 RACHMANINOFF: VOCALISE, OP.34 GRANADOS: INTERMEZZO FAURE: ELEGIE, OP.24 POPPER: ELFEN TANZ, OP.39 Recorded on July 22/23, 1976 in Tokyo</p>	<p>Stephen KATES, cello Shuku IWASAKI, piano</p>
<p>OX-7097</p>		<p>ANNEROSE SCHMIDT PLAYS CHOPIN-2 BALLADES NO.2, OP.38/NO.4 OP.52 BERCEUSE, OP.57 ETUDES OP.25-7/OP.25-8/OP.25-12 MAZURKAS NO.13, OP.17-4/NO.19, OP.30-2 NO.21, OP.30-4/NO.32, OP.50-3 Recorded on Nov. 7/8, 1976 in Tokyo</p>	<p>Annerose SCHMIDT, piano</p>







OX-7098		<p>MUSIC FOR FLUTE AND HARP MOZART: CONCERTO IN C MAJOR FOR FLUTE, HARP AND ORCHESTRA, KV299 LECLAIR: SONATA IN G MAJOR FOR FLUTE AND HARP C.P.E. BACH: SONATA IN D MAJOR FOR FLUTE AND HARP Recorded on Feb. 2/3, 1977 in Tokyo</p>	<p>Christian LARDE, flute Marie-Claire JAMET, harp Fumiki ASAZUMA conducting TOKIO AKADEMIKER ENSEMBLE</p>
OX-7099		<p>THE CELEBRATED MUSIC OF GERMAN BAROQUE BACH: TRIO SONATA for Flute, Oboe and Harpsichord HÄNDEL: SONATA for Cello and Harpsichord TELEMANN: TRIO SONATA for Flute, Oboe and Harpsichord TELEMANN: SONATA for Oboe and Harpsichord QUANTZ: TRIO SONATA for Flute, Oboe and Harpsichord Recorded on Mar. 16/17, 1977 in France</p>	<p>QUATUOR INSTRUMENTAL DE PARIS</p>
OX-7100		<p>SCHUMANN: FRAUENLIEBE UND LEBEN, OP.42 LIEDERKREIS, OP.39 Recorded on Dec. 10/11, 1976 in Tokyo</p>	<p>Vera SOUKUPOVA, alto Jan HORAK, piano</p>
OX-7101		<p>THREE CENTURIES OF RECORDER MUSIC CASTELLO: SONATA FOR SOPRANO RECORDER AND BASSO CONTINUO TELEMANN: FANTASIE NO.7 IN D MAJOR BARSANTI: SONATA IN F MAJOR HOTTETERRE: SUITE NO.4 IN D MAJOR VAN EYCK: PAVANE LACHRYMAE HANDEL: SONATA IN B-flat MAJOR Recorded on Aug. 3 & 5, 1976 in Copenhagen</p>	<p>Eva LEGENE, recorder Karen ENGLUND, harpsichord Adelheid GLATT, viola da gamba</p>
OX-7102		<p>BACH: INVENTIONS AND SINFONIAS BWV772a/801 Recorded on Mar. 21, 1977 in Tokyo</p>	<p>Andras SCHIFF, piano</p>
OX-7103		<p>TCHAIKOVSKY: CONCERTO IN D MAJOR FOR VIOLIN AND ORCHESTRA, OP.35 SERENADE MELANCOLIQUE Recorded on June 5 & 12, 1977 in Tokyo</p>	<p>Jean-Jacques KANTOROW, violin Akeo WATANABE conducting THE TOKYO METROPOLITAN SYMPHONY ORCHESTRA</p>
OX-7104		<p>SVETOSLAV OBRETENOV BULGARIAN CAPELLA CHOIR LIVE IN JAPAN MORFOV: DAMIAN TANEC VODI/BABA MINKOVCA HRISTOV: ERGEN DIADO/V TVOETO CARSTVO/RATCHENITCA DIMITROV: CAFNALO E DOKICHE CHESHMEDJIEV: NASTAPVANE NA NOSHTA PIPKOV: NANI MI, NANI DAMJANCHO SVESHTNIKOV: V TAMNATA GORA POLTAVCEV: VECHE PADNA MAGLA DUNAEVSKI: LETETE GALABI NOVIKOV: EU YXAEM RACHMANINOV: ITALIANICHE POLKA Recorded on May 19, 1977 in Japan</p>	<p>Georgy ROBEV conducting SVETOSLAV OBRETENOV BULGARIAN CAPELLA CHOIR Stanka MARKOVA, soprano Rumena BOBEVA, soprano</p>



<p>OX-7105**</p>		<p>BEETHOVEN : STRING QUARTETS NO.1 IN F MAJOR, OP.18-1 NO.5 IN A MAJOR, OP. 18-5</p> <p>Recorded on Apr. 6/7, 12→14, 1977 in Prague</p>	<p>SMETANA QUARTET</p>
<p>OX-7106</p>		<p>FRANCK : SONATA IN A MAJOR FOR VIOLIN AND PIANO</p> <p>BRAHMS : SONATA NO.3 IN D MINOR FOR VIOLIN AND PIANO, OP.108</p> <p>Recorded on July 7→9, 1976 in Tokyo</p>	<p>Rony ROGOFF, violin Samuel SANDERS, piano</p>
<p>OX-7107-8 (2 records set)</p>		<p>BACH : THE SIX PARTITAS BWV825-830</p> <p>Recorded on Apr. 13/14, 1977 in Tokyo</p>	<p>Yuji TAKAHASHI, piano</p>
<p>OX-7109</p>		<p>THE ORGAN CONCERT AT HOLMENS CHURCH</p> <p>MARTINI: SONATA SUI FLAUTI III BOYCE: VOLUNTARY IN D MAJOR TELEMANN: WIE SHON LEUCHTET DER MORGENSTERN PACHELBEL: CIACONA IN F MINOR BACH: FANTASIA AND FUGUE IN C MINOR, BWV537 BACH: JESUS, MEINE ZUVERSICHT, BWV728 BACH: HERZLICH TUT MICH VERLANGEN, BWV727</p> <p>Recorded on July 15 & 18, 1976 in Copenhagen</p>	<p>Jorgen Ernst HANSEN, organ</p>
<p>OX-7110**</p>		<p>JANACEK SINFONIETTA TARAS BULBA</p> <p>Recorded on Apr. 18 & 19, 1977 in Prague</p>	<p>Zdenek KOSLER conducting CZECH PHILHARMONIC ORCHESTRA</p>
<p>OX-7111</p>		<p>MOZART : SONATAS FOR PIANO AND VIOLIN-3 SONATA IN B-flat MAJOR, KV454 SONATA IN E-flat MAJOR, KV481</p> <p>Recorded on Feb. 21/22, 1977 in France</p>	<p>Alain PLANES, piano Jean-Jacques KANTOROW, violin</p>
<p>OX-7112</p>		<p>ROMANTIC PAGES FOR FLUTE AND HARP</p> <p>DONIZETTI: SONATA IN G MINOR DOPPLER: CASILDA-FANTASY SPOHR: SONATA IN E-flat MAJOR, OP.114 ROSSINI: ANDANTE CON VARIAZIONI</p> <p>Recorded on May 29/30, 1977 in Tokyo</p>	<p>Andras ADORJAN, flute Ayako SHINOZAKI, harp</p>
<p>OX-7113</p>		<p>VILLA-LOBOS: MUSIC FOR PIANO PROLE DO BEBE SUITE NO.1 "A familia do Bebe" (1918) VALSA DA DOR (1932) RUDEPOEMA (1926) CHOROS NO.5 "Alma Brasileira" (1926)</p> <p>Recorded on Apr. 11 & 21, 1977 in Tokyo</p>	<p>Arthur MOREIRA-LIMA, piano</p>





OX-7114**		DVORAK : PIANO TRIOS NO.1 IN B-flat MAJOR, OP.21 NO.2 IN G MINOR, OP.26 Recorded on Apr. 25→27, 1977 in Prague	SUK TRIO
OX-7116		TOURNEE EN EUROPE CLASSIQUE MOZART: ADAGIO AND RONDO, KV617 D'ANDRIEU: LA LYRE D'ORPHEE QUANTZ: TRIO SONATA IN C MINOR J.C. BACH: QUINTET IN D MAJOR, OP.XXII D'ANDRIEU: LA PASTORALE HAYDN: TRIO IN C MAJOR, HOB IV/1 Recorded on Oct. 7/8, 1977 in Tokyo	ENSEMBLE BAROQUE DE PARIS
OX-7117		J.S. BACH : THREE SONATAS FOR VIOLA DA GAMBA AND HARPSICHORD NO.1 IN G MAJOR, BWV1027 NO.2 IN D MAJOR, BWV1028 NO.3 IN G MAJOR, BWV1029 Recorded on Aug. 18 & 20, 1976 in Munich	Johannes FINK , viola da gamba Huguette DREYFUS , harpsichord
OX-7118		CHOPIN PIANO RECITAL FANTASIE-IMPROMPTU SCHERZO NO.2 BALLADE NO.3 ETUDES, OP.10, Nos.3 and 12 PRELUDES Nos.15 and 24 MAZURKA No.5 NOCTURNES No.2 and No.20 Recorded on Apr. 7/8, 1977 in Tokyo	Arthur MOREIRA-LIMA , piano
OX-7119		SCHUMANN : KREISLERIANA, Op.16 WALDSZENEN, OP.82 Recorded on Mar. 10/11, 1976 in Tokyo	Yuji TAKAHASHI , piano
OX-7120		GRIEG : HOLBERG SUITE, Op.40 BRITTEN SIMPLE SYMPHONY BARBER ADAGIO FOR STRINGS, Op.11 Recorded on July 16/17, 1977 in Tokyo	BAROQUE STRINGS ZURICH
OX-7121		MENDELSSOHN : SONGS WITHOUT WORDS A Collection from Op.19, 30, 38, 53, 62, 67 Recorded on Nov. 20, 1977 in Tokyo	John O'CONNOR , piano
OX-7122**		THE COMPLETE PIANO TRIOS DVORAK : PIANO TRIO No.3 IN F MINOR, Op.65 Recorded on May 2/3, 1977 in Prague	SUK TRIO
OX-7123		SCHUMANN : MUSIC FOR PIANO PAPILLONS, Op.2 ARABESKE IN C MAJOR, Op.18 HUMORESKE IN B-FLAT MAJOR, Op.20 Recorded on Mar. 14/15, 1977 in Tokyo	Andras SCHIFF , piano







<p>OX-7124</p>		<p>JAPANESE FAVOURITE MELODIES ON BAROQUE (SPRING) HANA ; SAKURA SAKURA ; HARU GA KITA (SUMMER) WARE WA UMINOKO ; AME ; UMI (AUTUMN) SATO NO AKI ; KOJO NO TSUKI ; CHIISAI AKI MITSUKETA (WINTER) PECHIKA ; YUKI NO FURU MACHIO ; HARU YO KOI Recorded on Feb. 7, 1978 in Tokyo</p>	<p>Masaaki HAYAKAWA conducting THE VIVALDI ENSEMBLE, TOKYO Transcription by Masaki HAYAKAWA</p>
<p>OX-7125</p>		<p>THE BEATLES CONCERTO for piano and orchestra FOOL ON THE HILL MICHELLE HEY JUDE THE LONG AND WINDING ROAD YESTERDAY AND I LOVE HER LET IT BE Record on Mar. 27/28, 1978 in Tokyo</p>	<p>Richard DEERING, piano Kentaro HANEDA, conducting TOKYO CHAMBER ORCHESTRA</p>
<p>OX-7126</p>		<p>TELEMANN CHAMBER WORKS-1 TRIO IN C MINOR SONATA IN G MAJOR QUARTET IN G MINOR QUARTET IN G MAJOR SONATA IN B MINOR TRIO IN A MAJOR Recorded on July 28/29, 1976 in Copenhagen</p>	<p>Jorgen Ernst HANSEN, harpsichord Members of "SOCIETAS MUSICA "</p>
<p>OX-7127</p>		<p>TELEMANN CHAMBER WORKS-2 TRIO IN G MINOR "CORELIZANTES V" CONCERTO IN C MAJOR TRIO IN D MAJOR SONATA IN G MINOR SONATA POLONESE IN C MAJOR Recorded on July 30/31, 1976 in Copenhagen</p>	<p>Jorgen Ernst HANSEN, harpsichord Members of "SOCIETAS MUSICA "</p>
<p>OX-7128</p>		<p>THE ORGAN CONCERT AT OUR SAVIOUR'S CHURCH SWEELINCK : FANTASIA "CROMATICA" J.S. BACH : PRELUDE AND FUGUE IN E MINOR BWV 548 "WEDGE" LISZT : PRELUDE AND FUGUE ON THE NAME B-A-C-H, G 260 FRANK : CHORAL NO.2 in B MINOR Recorded on Mar. 28-→30, 1977 in Copenhagen</p>	<p>Charley OLSEN, organ</p>
<p>OX-7129</p>		<p>JOHN O'CONOR PLAYS BEETHOVEN NO.17 IN D MINOR, OP.31 NO.2 "TEMPEST" NO.31 IN A-FLAT MAJOR, OP.110 Recorded on Nov. 6/7, 1977 in Tokyo</p>	<p>John O'CONOR, piano</p>
<p>OX-7130</p>		<p>NICOLET PLAYS J.S. BACH FLUTE SONATAS NO.1 IN G MAJOR, BWV525 NO.3 IN D MINOR, BWV527 IN G MAJOR BWV1038 IN C MINOR BWV1079 Recorded on Apr. 1 & 2, 1978 in Tokyo</p>	<p>Aurèle NICORET, flute Michio KOBAYASHI, harpsichord</p>

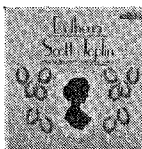
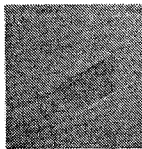





OX-7131**		<p>TWO STRINGS QUARTETS BORODIN : STRING QUARTET OP.2 IN D MAJOR</p> <p>PROKOFIEV: STRING QUARTET NO.2 IN F MAJOR, OP.92</p> <p>Recorded on Nov. 8→10, 1977 in Tokyo</p>	PRAGUE STRING QUARTET
OX-7132		<p>W.A. MOZART : FANTASIES ET RONDOS</p> <p>FANTASIE, KV.475 RONDO, KV.485 FANTASIE KV.397 RONDO KV.511</p> <p>Recorded in Tokyo in 1974</p>	Maria João PIRES, piano
OX-7133		<p>"LIEBESTRÄUME" The Most Beautiful Melodies for Harp</p> <p>LISZT: LIEBESTRÄUME J.S. BACH: AVE MARIA J.S. BACH: BOURREE DEBUSSY: LA FILLE AUX CHEVEAUX DE LIN SATIE: GYMNOPEDIES NO.1 & 3 FAURE: BERCEUSE, OP.16 DEBUSSY: CLAIR DE LUNE FAURE: SICILIENNE, OP.78 J.S. BACH: JESUS BLEIBET MEINE FREUDE</p> <p>Recorded on June 6, 12 & July 1, 1978 in Tokyo</p>	Ayako SHINOZAKI, harp ENSEMBLE LUNAIRE
OX-7134**		<p>THE COMPLETE PIANO TRIOS DVORAK :</p> <p>TRIO NO.4 IN E MINOR, OP.90 "DUMKY"</p> <p>SUK : ELEGY FOR PIANO TRIO, OP.23</p> <p>Recorded on May 11→13, 1978 in Prague</p>	SUK TRIO
OX-7135		<p>J. HAYDN: PIANO SONATAS</p> <p>SONATA IN C MAJOR, Hob.XVI/48 SONATA IN C MINOR, Hob.XVI/20 SONATA IN C MAJOR, Hob.XVI/50</p> <p>Recorded on May 29/30, 1978 in Tokyo</p>	Andras SCHIFF, piano
OX-7136		<p>KAZUO FUKUSHIMA (1930-) WORKS FOR FLUTE</p> <p>REQUIEM (1956) for flute Solo EKAGRA (1957) for alto flute and piano THREE PIECES FROM "CHU-U" (1959) for flute and piano MEI (1962) for flute solo KADHA-KARUNA VERSION II (1962) for flute and piano SHUN-SAN (1969-1977) for flute solo</p> <p>Recorded on July 11/12, 1977 in Tokyo</p>	Robert AITKEN, flute Yuji TAKAHASHI, piano
OX-7137		<p>TCHAIKOVSKY : SYMPHONY No.4 IN F MINOR, Op.36</p> <p>Recorded at Christuskirche, East Berlin on June 7, 8, 9, 12, 1978.</p>	Kurt SANDERLING, conducting BERLIN SYMPHONY ORCHESTRA
OX-7138**		<p>THE EARLY STRING QUARTETS BEETHOVEN : STRING QUARTET No.3 IN D MAJOR, Op.18 No.3/ STRING QUARTET No.6 IN B-FLAT MAJOR, Op.18 No.6</p> <p>Recorded at Suparphon Domovina Studio, Prague on May 22-25, 1978.</p>	SMETANA QUARTET

<p>OX-7139**</p>		<p>PANENKA PLAYS JANACEK AND SMETANA IN THE MIST/THE HOLY VIRGIN OF FRYDEK/SMETANA/POLKA/THE LANCER/ ON THE SEASHORE/A FAIRY TALE</p> <p>Recorded at Iino Hall, Tokyo on November 24, 25, 1976.</p>	<p>Jan PANENKA, piano</p>
<p>OX-7140</p>		<p>JANOS STARKER: VIRTUOSO MUSIC FOR CELLO HANDEL--WEINER: SICILIENE/PAGANINI: MOSES FANTASIE/FAURE: APRES UN UN REVE/POPPER: HUNGARIAN RHP- SODY, Op. 68/GRANADOS: INTERMEZZO FROM THE OPERA "GOYESCAS"/FALLA: DANSE RITUELLE DU FEU/DEBUSSY: LA FILL AUX CHEVEUX DE LIN/RAVEL: PIECE EN FORME DE HABANERA/ROSSINI- TEDESCO: FIGARO FROM "THE BARBER OF SEVILLE"</p> <p>Recorded at Nippon Columbia's 1st Studio, Tokyo, on June 20, 1978.</p>	<p>Janos STARKER, cello Shigeru NERIKI, piano</p>
<p>OX-7141**</p>		<p>SCHUBERT: FOUR WORKS FOR VIOLIN AND PIANO SONATA IN A MAJOR, Op. 162 (D.574) "DUO"/SONATINE IN D MAJOR, Op.137-- No. 1/SONATINE IN A MINOR, Op.137-- No.2/SONATINE IN G MINOR, Op.137-- No.3</p> <p>Recorded at Ishibashi Memorial Hall on December 10, 11, 1977.</p>	<p>Bohslav MATOUSEK, violin Petr ADAMEC, piano</p>
<p>OX-7142</p>		<p>YUJI TAKAHASHI: ITALIAN CONCERTO & FRENCH OVERTURE J.S. BACH: FRENCH OVERTURE BWV.831/ITALIAN CONCERTO BWV.971/FOUR DUET BWV. 802/805</p> <p>Recorded at Nippon Columbia's 1st Studio, Tokyo on June 22, 23, 1978.</p>	<p>Edition: The Neue Bach Ausgabe Yuji TAKAHASHI, piano</p>
<p>OX-7143</p>		<p>FRANCOIS COUPERIN: MESSE PROPRE POUR LES COUVENTS Pierre-Yves ASSELIN a le Grandes Orgues de Houdan (Alexandre Cliquot)</p> <p>Recorded at L'Eglise st. Christopher, Houdan on July 10, 11 & 12, '78.</p>	<p>Harry GERAERTS, tenor</p>
<p>OX-7144</p>		<p>W.A. MOZART: SONATAS FOR PIANO AND VIOLIN, VOL. 4 Sonatas in C Major, KV296 & 306 Sonata in D Major, KV306</p> <p>Recorded at L'Eglise Notre-Dame des Roses, Grisy, France on July 3, 4, 5, 6 & 7, '78.</p>	<p>Jean-Jacques KANTOROW, violin Alain PLANES, piano</p>



OX-7145		<p>LES CLAVECINISTES FRANCAIS F. Couperin-Les Fastes de la Grande et Ancienne Mxnstxndxssx/D'Anglebert-Devxieme/L. Couperin-Suite en do Majeur/Duphly-La de Belombre, La Felix, Lalanza</p> <p>Recorded at L'Eglise Notre-Dame des Roses, Grisy on Feb. 12 & 13, '77.</p>	<p>Yannick Le GAILLARD, clavecin (William Dowd, Paris)</p>
OX-7146		<p>CLASSICS ON SCREEN Marcello: ADAGIO/Albinoni: ADAGIO/Pachelbel: CANON AND GIGUE/Mozart: ANDANTE DIVERTIMENTO/Bizet: LES TOREADORS/Chopin: NOCTURNE/Mozart: ANDANTINO-CONCERTO/J.S. Bach: LARGO-CONCERTO/Beethoven: MOLTO VIVACE-Symphony No.9 "Choral"/Beethoven: ADAGIO CANTABILE</p> <p>Recorded on Nov. 2 & 4, 1978 in Japan</p>	
OX-7147		<p>ROMANTIC CELLO MINIATURES Saint-Saens: LE CYGNE/Faure: APRES UN REVE, SICILIENNE, ELEGIE/Ravel: BERCEUSE/Bruch: KOL NIDOREI/Casals: CANT DELL OCELLS/Falla: NANA y JOTA/J.S. Bach: ERBARME DICH, MEI GOTT</p> <p>Recorded at Nippon Columbia's 1st studio on Oct. 17 & Dec. 21, '78.</p>	<p>Mari FUJIWARA, violincello Michiko OKAMOTO, piano (Steinway)</p>
OX-7149		<p>SCARLATTI: 14 SONATAS FOR HARPSICHORD K 337, 338, 191, 532, 533, 234, 203, 477, 534, 535, 418, 419, 546, 547</p> <p>Recorded at L'Eglise Notre-Dame des Roses, Grisy-Suisne on July 1, 2 & 3, '78.</p>	<p>Huguette DREYFUS, harpsichord (Henri Hemsch, Paris)</p>
OX-7150		<p>J.S. Bach: INVENTIONS AND SINFONIAS</p> <p>Recorded at L'Eglise Notre-Dame des Roses, June 30, 1978.</p>	<p>Huguette DREYFUS, harpsichord (Hemsch, Paris)</p>
OX-7151		<p>SMETANA QUARTET IN CONCERT-1 —Recorded live at their 1978 Concerts in Japan— SCHUBERT: String Quartet No.14 In D Minor, D.810 "DEATH AND THE MAIDEN" SCHUBERT: String Quartet No.10 In E-Flat Major, Op.125 No.1, D.87 Allegro</p> <p>Recorded at Aichi Bunka Kohdo, on November 15, 1978 and at Gifu Shimin Kaikan on November 14, 1978.</p>	<p>SMETANA QUARTET</p>
OX-7152		<p>SMETANA QUARTET IN CONCERT 2 —Recorded live at their 1978 concerts in Japan— DVORAK: String Quartet No.12 (No.6) in F Major, Op.96 "AMERICAN"/Quintet in A Major for Piano and String Quartet, Op.81</p> <p>Recorded at Gifu Shiminkaikan, Japan, November 14, 1978 and at Shinjuku Koseinenkin Kaikan, Tokyo, Japan, November 18, 1978</p>	<p>SMETANA QUARTET Josef HAR, piano</p>

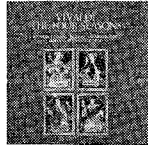



<p>OX-7153</p>		<p>BIZET : L'ARLESIEUNNE SUITE/CARMEN SUITE</p> <p>Recorded at Yomiuri Nippon Symphony Orchestra Rehearsal Hall, November 2/4, 1978.</p>	<p>Rainer MIEDEL conducting YOMIURI NIPPON SYMPHONY ORCHESTRA</p>
<p>OX-7154</p>		<p>THE ARTISTRY OF BRUNO GIURANNA</p> <p>SHUBERT SONATA IN A MINOR FOR ARPEGGIONE AND PIANO D821 (Viola-and-Piano Version) VIEUXTEMPS SONATA IN B-FLAT MAJOR FOR VIOLA AND PIANO Op.36</p> <p>Recorded at Arakawa Kumin Kaikan, May 11/12, 1978.</p>	<p>Bruno GIURANNA, viola Shuku IWASAKI, piano (Steinway)</p>
<p>OX-7155</p>		<p>DEBUSSY/RAVEL</p> <p>DEBUSSY: CLAIR DE LUNE/CHILDREN'S CORNER RAVEL: MA MERE L'OYE/PAVANE POUR UNE INFANTE DÉFUNTE</p> <p>Recorded at Ishibashi Memorial Hall, Tokyo, January 9/10, 1979 and August 8/9, 1978.</p>	<p>Keiko NOSAKA et ENSEMBLE DE L'ÉCOLE DE KOTO AVEC VINGT CORDES</p>
<p>OX-7156</p>		<p>MOZART :</p> <p>Symphony No.38 in D Major, KV504 "PRAGUE"/Symphony No.36 in C Major, KV 425 "LINZ"</p> <p>Recorded at Arakawa Kumin Kaikan, Tokyo on January 6, 1979.</p>	<p>Otmar SUITNER, conducting NHK SYMPHONY ORCHESTRA</p>
<p>OX-7157</p>		<p>MENDELSSOHN: WORKS FOR PIANO</p> <p>Rondn Capriccioso In E Major, Op.14/Three Fantasies or Caprices, Op.16/Fantasy in F-Sharp Minor, Op.28 ("Scottish Sonata")/Scherzo a Capriccio in F-Sharp Minor</p> <p>Recorded at Nippon Columbia's 1st Studio on November 6, 7, 1977.</p>	<p>John O'CONNOR, piano (Steinway)</p>
<p>OX-7158</p>		<p>SCOTT JOPLIN :</p> <p>"BETHENA" and other Ragtime Music The Entertainer/The Ragtime Dance/The Sycamore/The Chrysanthemum*/Klite Syncopations/Bethena/Original Rag/The Favorite*/The Strenuous Life/Maple Leaf Rag</p> <p>Recorded on Jan. 5, 1979 in Tokyo</p>	<p>Andras ADORJAN, flute Masahiko SATOH, piano Iso-o FUKUI, bass*</p>
<p>OX-7159-60 (2 records set)</p>		<p>DIE KLAVIERMUSIC DER NEUEN WIENER SCHULE</p> <p>SCHOENBERG: Funf Klavieratucke, Op.23 Suite fur Klavire, Op.25 Drei Klavierstucke, Op.11 Sechs Kleine Klavierstuke, Op.19 Klavierstuck, Op.33 a/b</p> <p>WEBERN: Variationen, Op.27 Kinderstuck Klavierstuck, Op. post Sonatensatz (Rondo) fur Klavier Sate fur Klavier</p> <p>BERG: Sonate fur Klavier, Op.1</p> <p>SCHOENBERG: Fruhe Klavierstucke (Erste Aufnahme) Three Pieces Sechs Stuke fur Klavier zu vier Handen</p> <p>Recorded at Arakawa Public Hall, Tokyo, & Nippon Columbia No.1 Studio in 1977</p>	<p>Yuji TAKAHASHI, klavier (Steinway) Ryuichi SAKAMOTO, 2es klavier</p>

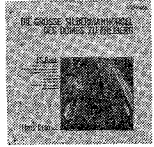

OX-7161		<p>MUSIC FOR WIND REICHA: Wind Quintet in E-Flat Major, Op. 88, No.2 ROSSINI: Wind Quartet No.6 in F Major DANZI: Wind Quintet in G Minor, Op.56, No.2 VIVALDI: Sonata in G Minor for Flute, Oboe and Fagot</p> <p>Recorded at Nôtre-Dame des Roses, Grisy, France on March 6, 7, 1977.</p>	<p>TAFFANEL WIND QUINTET</p>
OX-7162		<p>FLORILEGE DE LA MUSIQUE POUR FLUTE FAURE: Sicilienne, Op.78/GLUCK: Scece des Champs-Elysees de "Orphee "/>DEBUSSY: La Fille Aux Cheveux De Lin/RAVEL: Pavane Pour Une Infante Defunte/BIZET: Menuet de Suite No.2 " L'Arlesienne "/>DEBUSSY: Syrinx/FAURE: Fantasie, Op.79/FAURE: Berceuse, Op.16/RAVEL: Piece En Forme De Habanera/HONEGGER: Danse de la Chevre/GENIN: Carnaval de Venise, Op.14</p> <p>Recorded at Nippon Columbia's 1st Studio on September 22, 23, 1978.</p>	<p>Maxence LARRIEU, flute Toshiko KIRYU, piano</p>
OX-7163		<p>SCHUMANN: TWO SONATAS FOR VIOLIN AND PIANO Sonata No.1 in A Minor for violin and piano, Op.105/Sonata No.2 in D Minor for Violin and Piano, Op.121</p> <p>Recorded at L'Eglise Nôtre-Dame des Roses, Grisy-suisne on February 23, 24, 1977.</p>	<p>Jean-Jacques KANTOROW, violin Alain PLANES, piano</p>
OX-7164		<p>VLADIMIR MIKULKA GUITAR RECITAL TERZI: Nevicata Pastorale, Op.29/RAK: Variace Na Tema Jaromira Klempire/ TORROBA: Burgalesa/TORROBA: Nocturno/BARRIOS: La Catedral/KOSHKIN: Andante Quasi Passacaglia E Toccata/ RODRIGO: Sarabande Lointaine/BROUWER: Elogio de la Danza/VILLA-LOBOS: Etude No.7</p> <p>Recorded at Nippon Columbia's 1st Studio on April 2, 4, 6, 1979.</p>	<p>Vladimir MIKULKA, guitar</p>
OX-7165		<p>DE LA PERIODE HUMORISTIQUE D'ERIK SATIE</p> <p>Recorded at Nippon Columbia No.1 Studio, Tokyo, Mar. 12 & 13, '79.</p>	<p>Yuji TAKAHASHI, piano (Steinway) Keiko MIZUNO, violin</p>
OX-7166-7 (2 records set)		<p>J.S. BACH: ORGELBUCHLEIN</p> <p>Recorded on Mar. 23→27, 1977 in Copenhagen</p>	<p>Jorgun ERNST HANSEN at the organ of Holmens Church, Copenhagen, on Mar. 23, 1977</p>
OX-7168		<p>BEETHOVEN: String Quarter No.7 in F Major, Op.59, No.1 " Rasumovsky No.1 "</p> <p>Recorded at Supraphon Domovina Studio, Prague on 29, 30 & 31, 1978.</p>	<p>SMETANA QUARTET (Jiri Novak, Lubomir Kostecky, violins Milan Skampa, viola, Antonin Kohout, violoncello)</p>

<p>OX-7169</p>		<p>W.A. MOZART: SONATAS FOR PIANO AND VIOLIN VOL.5 Sonata in E Minor, KV304(300c)/Sonata in G Major, KV301(293a)/Sonata in G Major, KV 379(373a)/Andante and Allegretto in C Major, KV404(385d) Recorded on Dec. 11 & 14, 1975 in France</p>	<p>Jean-Jacques KANTOROW, violin Alain PLANES, piano</p>
<p>OX-7170</p>		<p>ANNEROSE SCHMIDT PLAYS CHOPIN, VOL.3 Fantaisie in F Minor, Op.49/Polonaise-Fantaisie in A-Flat Major, Op.61/Polonaise in F-Sharp Minor, Op.44/Noctume in B Major, Op.62, No.1/Nocturne in E Major, Op.62, No.2 Recorded at Nippon Columbia No.1 Studio, Tokyo, Nov. 21 & 22, 1976.</p>	<p>Annerose SCHMIDT, piano (Steinway)</p>
<p>OX-7171</p>		<p>JANOS STARKER PLAYS CASSADO, SCHUBERT, CHOPIN GASPAR CASSADO: Suite per violoncello sollo SCHUBERT: Sonatine in D Major Op.137, No.1 (D384) for violoncello and piano CHOPIN: Sonata in G Minor for violoncello and piano, Op.65 Recorded at Nippon Columbia No.1 Studio on June 20 & 24, 1978.</p>	<p>Janos STARKER, violoncello Shigeo NERIKI, piano</p>
<p>OX-7172</p>		<p>FLORILEGE DE LA MUSIQUE BAROQUE ITALIENNE VIVALDI: Sonata No.12 En Re Mineur "Folia"/BOCCHERINI: Sonata En La Majeur Pour Violoncello Et Clavecin/dall'ABACO: Sonata En la Majeur Pour Flute, Hautbois Et Basso Continuo, Op.3, No.12/FRESCOBALDI: Canzoni a due canti/LOTTI: Sonata En Sol Majeur Pour Flute, Violoncelle Et Clavecin Recorded at L'Eglise Notre-Dama des Roses, Grisy-suisne, France on July 9-11, 1975.</p>	<p>QUATUOR INSTRUMENTARE DE PARIS</p>
<p>OX-7173</p>		<p>J.P. SWEELINCK: THE ORGAN WORKS Mein Junges Leben Hat Ein End'/Toccata ex C/Echo Fantasia ex C/Praeludium in F/Allein Gott in Der Hoh Sei EHR/Echo Fantasia ex A/Hexachord Fantasia/Ballo Del Granduca Recorded at St. Janskerk, Schiedam, Netherlands on June 23-24, 1978.</p>	<p>JACQUES VAN OORTMERSSEN, at the Organ of Grote of St. Janskerk, Schiedam (Heijndrick Neijenhoff 1553—A.D. Fientrop 1975)</p>
<p>OX-7174</p>		<p>ANTONIO VIVALDI: THE FOUR SEASONS Recorded at Ishibashi Memorial Hall, Tokyo on Apr. 14/15, 1979.</p>	<p>Gunars LARSENS, violin FESTIVAL STRINGS LUCERNE Direction: Rudolf Baumgartner</p>
<p>OX-7175</p>		<p>J.C. BACH: THREE CONCERTOS FOR HARPSICHORD AND STRINGS Concerto in G Major/Concerto in A Major/Concerto in F Minor Recorded TOKYO SOLISTEN at Columbia Grand Studio on Apr. 29 & 30, 1978.</p>	<p>Huguette DREYFUS, harpsichord (William Dowd, Paris 1977 after J.H. Hemsch, Paris 1761)</p>

OX-7176		<p>W.A. MOZART SONATAS FOR PIANO AND VIOLIN VOL: 6</p> <p>Sonata in E-Flat Major, KV302 (293b) Sonata in A Major, KV305 (293d) Sonata in F Major, KV547</p> <p>Recorded at L'Eglise Nôtre-Dame des Roses, France on July 7/9, 1978.</p>	<p>Jean-Jacques KANTOROW, violin Alain PLANES, piano</p>
OX-7177		<p>THE FLOWERS OF PIANO MUSIC</p> <p>Beethoven: FOR ELISE/Schubert: MOMENT MUSICAL NO.3 IN F MINOR, OP.94, NO.3/ Debussy: CLAIR DE LINE/Schumann: TRAUMEREI, OP.15, NO.7/Schumann: ROMANCE, OP.28, NO.2/Handel: THE HARMONIOUS BLACKSMITH/Chopin: NOCTURNE NO.2 IN E-FLAT MAJOR, OP.9, NO.2/ Chopin: NOCTURNE NO.19 IN E MINOR, OP.72, NO.1/Sibelius: ROMANCE, OP.24, NO.9/Mozart: TURKISH MARCH/Mozart: FANTASIA IN D MINOR, KV397</p> <p>Recorded at Nippon Columbia's 1st Studio On July 7/10, 1979.</p>	<p>John O'CONNOR, piano (Steinway)</p>
OX-7178**		<p>BEETHOVEN: STRING QUARTET NO.8 IN E MINOR, OP. 59, NO.2</p> <p>"RASUMOVSKY NO.2"</p> <p>Redorded at Dvorak Hall (House of Artist) on Aug. 8, 9, 12 & 13, 1979.</p>	<p>SMETANA QUARTET Jiri Novak, Lubomir Kostecky, violin</p> <p>Milan Skampa, viola Antonin Kohout, violoncello</p>
OX-7179		<p>ERIK SATIE: PIECES POUR PIANO A QUATRE MAINS</p> <p>(A) PARDE* --ballet realiste en un tableau CINEMA** --Entr'acte symphnique de "RELACHE"</p> <p>(B) TROIS MORCEAUX EN FORME DE POIRE (1903)*** APERCUS DESAGREABLES(1908-1912)**** LA BELLE EXCENTRIQUE***** --Fantaisie serieuse</p> <p>Recorded at Arakawa Kumin-Kaikan, Tokyo on Nov. 13 & 14, 1979.</p>	<p>Yuji TAKAHASHI, piano prima***)****) seconda*)****)*****)</p> <p>Alain PLANES, piano prima*)****)*****) seconda***)****)</p>
OX-7180		<p>W.A. MOZART: THE COMPLETE WORKS FOR FLUTE & ORCHESTRA IN TWO VOLUMES VOL.1</p> <p>Concerto No.1 in G Major for Flute & Orchestra KV313 Concerto No.2 in D Major for Flute & Orchestra KV314 Andante in C Major for Flute & Orchestra KV315</p> <p>Recorded at Hochschule fur Musik, Munchen on August 20, 21, 1979.</p>	<p>Andras ADORJAN, flute Hans STADLMAIR conducting MUNCHENER KAMMERORCHESTER</p>



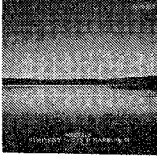

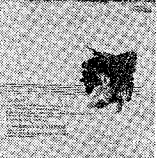
<p>OX-7181</p>		<p>W.A. MOZART : THE COMPLETE WORKS FOR FLUTE & ORCHESTRA IN TWO VOLUMES VOL. 2 Concerto in C Major for Flute, Harp & Orchestra KV299 Concertone in C Major for flute, Violin, Oboe, Violoncello & Orchestra KV190 Rondo in D Major for Flute & Orchestra KV Anh.184</p> <p>Recorded at Hochschule fur Musik, Munchen on August 22, 23, 1979.</p>	<p>Andras ADORJAN, flute Susanna MILDONIAN, harp Jean-Jacques KANTOROW, violin Diethelm JONAS, oboe Emmerich BUNEMANN, violoncello Hans STADLMAIR conducting MUNCHENER KAMMERORCHESTER</p>
<p>OX-7182</p>		<p>J.S. BACH : THREE KEYBOARD CONCERTOS Concerto in D Minor, BWV1052 Concerto in A Major, BWV1055 Concerto in F Minor, BWV1056</p> <p>Recorded at Henry Wood Hall, London on August 29, 30, 1979.</p>	<p>Andras SCHIFF, piano (Steinway) George MALCOLM conducting ENGLISH CHAMBER ORCHESTRA</p>
<p>OX-7183</p>		<p>TCHAIKOVSKY : SYMPHONY NO.6 IN B MINOR, OP.74 "PATHETIQUE"</p> <p>Recorded at Christuskirche, Berlin DDR on Sept. 19-22, 1979.</p>	<p>Kurt SANDERLING conducting BERLIN SYMPHONY ORCHESTRA</p>
<p>OX-7184</p>		<p>DIE GROSSE SILBERMANNORGEL DES DOMES ZU FREIBERG/J. S. BACH Toccatà Con Fuga d-moll, BWV 565 SECHS CHORALE VON VERSCHIEDENER ART...(Schübler) Praeludium Et Fuga g-moll, BWV 535 Trio c-moll, BWV 585 Fantasia G-dur, BWV 570 Trio G-dur, BWV 586 Praeludium Et Fuga C-dur, BWV 545 Fuga g-moll, BWV 578</p> <p>Recorded on Oct. 1-5, 1979. Koproduktion mit VEB Deutsche Schallplatten DDR/Berlin</p>	<p>Hans OTTO, orgel (die grosse silbermannorgel des Domes zu Freiberg)</p>



OX-7185		<p>HEINZ HOLLIGER : CHAMBER MUSIC FOR OBOE AND STRINGS</p> <p>W. A. Mozart: Adagio In C Major For English Horn, Violin, Viola and Violoncello, KV 580 a J. M. Haydn: Divertimento in C Major For Oboe, Viola, and Contrabass, P. 98 J. C. Bach: Quartet In B-Flat Major For Oboe, Violin, Viola and Violoncello J. M. Haydn: Quartet In C Major For English Horn, Violin, Violoncello and Contrabass, P. 115</p> <p>Recorded at Nippon Columbia No. 1 studio on Nov. 28/29, 1979.</p>	<p>Heinz HOLLIGER, English horn and oboe Antonio SALVATORE, violin Massimo PARIS, viola Vito PATERNOSTER, violoncello Lucio BUCCARELLA, Contrabass</p>
OX-7186		<p>TSCHAIKOVSKY : SYMPHONY NO. 5 IN E MINOR, OP. 64</p> <p>Recorded at Christuskirche, Berlin DDR on Sept. 25-29, 1979 Coproduction with VEB Deutsche Schallplatten</p>	<p>Kurt SANDERLING conducting BERLIN SYMPHONY ORCHESTRA</p>
OX-7187		<p>CLAUDE DEBUSSY Deux Arabesques Suite Bergamasque Children's Corner</p> <p>Recorded at Arakawa Kumin Kaikan, Tokyo on Nov. 6-8, 1979.</p>	<p>Alain PLANES, piano (Steinway)</p>
OX-7188		<p>L. V. BEETHOVEN STRING QUARTET NO. 9 IN C MAJOR, Op. 59, No. 3 "RASOUMOVSKY NO. 3" STRING QUARTET NO. 10 IN E-FLAT MAJOR, Op. 74 "HARP"</p> <p>Recorded at Dvorak Hall, House of Artists, Prague on Oct. 14/20, 1979.</p>	<p>SMETANA QUARTET</p>

<p>OX-7189</p> 	<p>RACHMANINOFF: PIANO MUSIC Kreisler-Rachmaninoff: Liebesfreud Kreisler-Rachmaninoff: Liebesleid Etude-Tableau in F-Sharp Minor, Op. 39, No. 3 Etude-Tableau in E-Flat Minor, Op. 39, No. 5 Etude-Tableau in D-Major, Op. 39, No. 9 Prelude in C-Sharp Minor, Op. 3, No. 2 Prelude in E-Flat Major, Op. 23, No. 6 Prelude in C-Minor, Op. 23, No. 7 Prelude in B-Flat Minor, Op. 32, No. 2 Prelude in G-Major, Op. 32, No. 5 Prelude in B-Minor, Op. 32, No. 10 Prelude in B-Major, Op. 32, No. 11 Prelude in G-Sharp Minor, Op. 32, No. 12</p> <p>Recorded at Nippon Columbia No. 1 Studio on Sept. 30, Oct. 1 & 2, 1978.</p>	<p>Jeffrey SIEGEL, Piano (Steinway)</p>
<p>OX-7190</p> 	<p>SIBELIUS: SYMPHONY NO. 2 IN D MAJOR, OP. 43</p> <p>Recorded at Arakawa Kumin Kaikan, Tokyo on Apr. 8 & 9, 1980.</p>	<p>Moshe ATZMON conducting THE TOKYO METROPOLITAN SYMPHONY ORCHESTRA</p>
<p>OX-7191</p> 	<p>ROMANTIC MELEDIES FOR CLASSIC GUITAR Folk Song: Romance Granados: Danza Española No. 5 Malats-Tárrega: Serenata Española Alard-Tárrega: Estudio Brillante Sor: Variations sur l'air, Op. 9 Tárrega: Recuerdos de la Alhambra Albéniz: Mallorca Ponce: Scherzino Mexicano Villa-Lobos: Chôro No. 1 Barrios: Chôro da Saudade</p> <p>Recorded at Niiza Public Hall, Saitama-pref., Japan on Apr. 16 & 17, 1980.</p>	<p>Machiko KIKUCHI, guitar</p>
<p>OX-7192**</p> 	<p>SMETANA QUARTET IN PRAGUE CONCERT LEOS JANACEK: STRING QUARTET NO. 1 inspired by Tolstoi's "KREUTZER SONATA" STRING QUARTET No. 2 "INTIMATE PAGES"</p> <p>Recorded live at the Dvorak Hall, Prague on Oct. 10, 1979</p>	<p>SMETANA QUARTET</p>
<p>OX-7193-5</p>  <p>(3 records set)</p>	<p>KATSUYA YOKOYAMA/SANGAI-RINTEN SANGAI-RINTEN/SESSHIN/FUTATSU-NO- UTA/RIRIURA/ONKU/MAKIRI/SOKKAN/ KODEN-SUGOMORI/SANAN/TAKIOTOSHI/ SHIKA-NO-TOHNE/UKIGUMO/SANYA- SUGAGAKI</p>	<p>Katsuya YOKOYAMA, Yoshikazu IWAMOTO, Tatsumi YOSHIOKA, Tadashi TAJIMA, Kazushi MATAMA, Terno FURUYA, Ichiro SEKI, Kuniyoshi SUGAWARA, shakubachi Kinshi TSURUYA, biwa & uta Sumire YOSHIWARA, Toshio OGURA, perc. Tadashi SAWAI, jushichigen-sou Yuusho KOJIMA, shoumyo</p>
<p>OX-7196</p> 	<p>J. S. BACH/THREE CONCERTOS FOR VIOLIN, STRING ORCHESTRA AND CONTINUO CONCERTO IN A MINOR, BWV1041 CONCERTO IN D MINOR, BWV1043 CONCERTO IN E MAJOR, BWV1042</p> <p>Recorded at Hochschule fur Musik, Munich on Aug. 24/25, 1979.</p>	<p>Jean-Jacques KANTOROW, violin Sigrid CENARIU, violin Hans STADLMAIR conducting MUNCHENER KAMMER ORCHESTER</p>

OX-7197		<p>G. F. HAENDEL: FOUR SONATAS FOR VIOLIN AND HARPSICHORD</p> <p>SONATA NO.1 IN A MAJOR, OP.1, NO.3 SONATA NO.3 IN F MAJOR, OP.1, NO.12 SONATA NO.4 IN D MAJOR, OP.1, NO.13 SONATA NO.6 IN E MAJOR, OP.1, NO.15</p> <p>Recorded at The Grange de la Besnardiere on June 30, July 1/2, 1975</p>	<p>Josef SUK, violin (Stradivari "The Tate" 1710) Zuzana RUZICKOVA, harpsichord (Georg Zahl)</p>
OX-7198*		<p>CLASSICAL MUSIC FROM FILMS</p> <ol style="list-style-type: none"> 1. "Kramer vs Kramer"/Vivaldi: Allegro-Concerto in C Major for Mandolin 2. "Anonimo Veneziano"/A. Marcello: Adagio-Concerto in C Minor for Oboe and Strings 3. "La Maison De Bories"/Mozart: Andante-Divertimento in D Major 4. "Les Amants"/Brahms: Andante Ma Moderato-String Sextet No. 1 in B-Flat Major 5. "Jeux Interdits"/Anonymous: Romance 6. "The Turning Point"/Wieniawski: Legende 7. "Le Ponces"/Albinoni Adagio in G Minor for Strings and Organ 8. "Tristana"/Chopin: Etude In C Minor "Revolutionary" 9. "Gruppo Di Famiglia In Un Interno"/Mozart: Adagio-Sinfonia Concertante in E-Flat Major 10. "Le Feu Follet"/Satie: Gnosienne No.1 11. "L'Innocente"/Chopin: Berceuse 	<p>Masayuki KAWAGUCHI, mandolin /Takashi TSUNODA, lute (1) "Societas Musica" Chamber Orchestra (2) Sofia Chamber Orchestra (3) Ensemble Instrumental "Musica Poetica" (4) Machiko KIKUCHI, guitar (5) Keiko MIZUNO, violin/Haruhi HATA, piano (6) "Societas Musica" Chamber Orchestra (7) Annerose SCHMIDT, piano (8) Gerard JARRY, violin/Serge COLLOT, viola/J-F. PAILLARD Conducting ORCHESTRE J-F. PAILLARD (9) Yuji TAKAHASHI, piano (10) Haruhi HATA, piano (11)</p>
OX-7199		<p>ADAGIOS FOR LOVERS</p> <ol style="list-style-type: none"> 1. Albinoni: Adagio in G Minor for Strings and Organ 2. Mozart: Adagio and Rondo in C Minor 3. Purcell: Chaconne in G Minor for 4 Voices 4. Vivaldi: Largo-Concerto in F Minor "Winter" 5. Mozart: Adagio and Fugue in C Minor 6. A. Marcello: Adagio-Concerto in C Minor for Oboe and Strings Orchestra 7. Pachelbel Canon for Three Violins and Continuo 8. Barber: Adagio for Strings 	<p>Joergen Ernst HANSEN conducting "Societas Musica" Chamber Orchestra (1, 3, 6, 7) ENSEMBLE BAROQUE DE PARIS (2) Rudolf BAUMGARTNER conducting FESTIVAL STRINGS LUCERNE (4) Ensemble Instrumental "Musica Poetica" (5) Joergen SKYTTEGAARD, oboe (6) BAROQUE STRINGS ZURICH (8)</p>
OX-7200*		<p>ENCORES WITH FLOWERISH</p> <ol style="list-style-type: none"> 1. Faure: Sicilienne 2. Schubert: Moment Musical No.3 3. Faure: Berceuse 4. Saint-Saens: The Swan 5. Mozart: Rondo in A Minor 6. Falla: Danse Rituelle Du Feu 7. Debussy: La Fille Aux Cheveux De Lin 8. Faure: Apres Un Reve 9. Liszt: Liebestraume 10. Debussy: Claire De Lune 11. Tarrega Recuerdos De La Alhambra 12. Joplin: Bethena-A Concert Walts 13. Kreisler: Liebeslied 14. Chopin: Nocturne No.2 in E-Flat Major 	<p>Maxcenc LARRIEU, flute/Toshiko KIRYU, piano (1, 7) John O'CONOR, piano (2, 14) Jean-Jacques KANTOROW, violin/ Alain PLANES, piano (3) Mari FUJIWARA, cello/Michiko OKAMOTO, piano (4, 8) Maria-Joao PIRES, piano (5) Janos STARKER, cello/Shigeo NERIKI, piano (6) Ayako SHINOZAKI, harp (9) Alain PLANES, piano (10) Machiko KIKUCHI, guitar (11) Andras ADORJAN, flute/Machiko SATOH, piano (12) Gerard JARRY, violin/Shuku IWASAKI, piano (13)</p>







<p>OX-7201***</p>		<p>BACH: LYRICAL THEMES</p> <ol style="list-style-type: none"> 1. Air-Suite No.3 in D Major 2. Mennuet in G Major "Notenbuch der A. M. Bach" 3. Largo-Concerto for Clavier in F Minor 4. Prelude in C Major "Das Wohltemperierte Klavier I" 5. Choral: Vor deinen Thron tret'ich 6. Choral: Jesus b'leibet meine Freude 7. Ricercare in 3 Voices "Musicalisches Opfer" 8. Siciliano-Sonata for Flute and Harpsichord in E-Flat Major 9. Andante-Italian Concerto in F Major 10. Choral: Wachet auf, ruft uns die Stimme 11. Sinfonia in F Minor 12. Aria: Erbarme dich, mein Gott-"Matthaus Passion" 13. Fuga in G Minor 14. Ricercare in 6 Voices-"Musicalisches Opfer" 	<p>Joergen Ernst HANSEN conducting "Societas Musica" Chamber Orchestra (1) Yuji TAKAHASHI, harpsichord (2,4) Yuji TAKAHASHI, piano/TOKYO BACH PLAYERS (3) Knud VAD, organ (5,6) Solists of ORCHESTRE DE CHAMBRE DE J-F. PAILLARD/ Maxence LARRIEU, flute (7) Andras ADORJAN, flute (8) Hugnette DREYFUS, harpsichord (8,11) Yuji TAKAHASHI, piano (9) Hans OTTO, organ (10) Mari FUJIWARA, violoncello/ Michiko OKAMOTO, piano (12) Helmut RILLING, organ (13) Solists of ORCHESTRE DE CHAMBRE DE J-F. PAILLARD (14)</p>
<p>OX-7202</p>		<p>BEETHOVEN: SYMPHONY NO.3 IN E-FLAT MAJOR, OP.55 "EROICA"</p> <p>Recorded on July 23-25, 1980 at Christuskirche, East Berlin</p>	<p>Otmar SUITNER conducting STAATSKAPELLE BERLIN</p>

<p>OB-7333-4 (2 records set)</p>		<p>BEETHOVEN : SXMPHONY NO.9 IN D MINOR, OP. 125 "CHORAL "</p> <p>Recorded Live at Tokyo Bunka Kaikan on December 3, 1976</p>	<p>Vaclav NEUMAN conducting CZECH PHILHARMONIC OR- CHESTRA PRAGUE PHILHARMONIC CHOIR Jalmira SMICKOVA, soprano Vera SOUKUPOVA, alto Vilém PRIBYL, tenor Richard NOVAK, baritone</p>
<p>OB-7335-6 (2 records set) —45 rpm—</p>		<p>THE SPECTACULER CONCERT BY FOUR FAMOUS ORGANS</p> <p>BACH: TOCCATA AND FUGUE IN D MINOR, BWV565 BACH: CHORAL "WACHET AUF, RUFT UNS DIE STIMME" BWV645</p> <p>PACHELBEL: CIACONA IN F MINOR BOYCE: VOLUNTARY IN D MAJOR</p> <p>BACH: FUGUE IN G MINOR "LITTLE FUGUE" BWV578 ALBINONI: CONCERTO IN F MAJOR BACH: CHORAL "JESUS BLEIBET MEINE FREUDE" BWV147</p> <p>LISZT: PRELUDE AND FUGUE</p>	<p>Helmuth RILLING, at the Organ of Gedächtniskirche, Stuttgart</p> <p>Jorgen Ernst HANSEN, at the Organ of Holmens Church, Copenhagen</p> <p>Knud VAD, at the Organ of Soro Church, Denmark</p> <p>Charley OLSEN, at the Organ of Our Saviour's Church, Copenhagen</p>
<p>OB-7337-8** (2 records set) —45 rpm—</p>		<p>THE BRILLIANT CONCERT FOR FAMOUS CHAMBER MUSIC</p> <p>HAYDN: 1st Mov. from STRING QUARTET IN D MAJOR, OP.64 "LARK" MOZART: 1st Mov. of STRING QUARTET IN B-FLAT MAJOR, KV.458 "HUNT" SCHUBERT: 2nd Mov. from STRING QUARTET IN D MINOR, D810 "DEATH AND THE MAIDEN" SCHUBERT: NOTTURNO IN E-FLAT MAJOR FOR PIANO, VIOLIN AND VIOLONCELLO OP.148 BORODIN: 3rd Mov. from STRING QUARTET IN D MAJOR MOZART: 1st Mov. from STRING QUINTET IN G MINOR, KV.516</p>	<p>BERLIN STRING QUARTET SMETANA QUARTET PRAGUE STRING QUARTET SUK TRIO JOSEF SUK, 1st violin in KV.516</p>
<p>OB-7339-40 (2 records set) —45 rpm—</p>		<p>THE BRILLIANT CONCERT FOR PIANO AND HARPSICHORD</p> <p>CHOPIN: ETUDE IN C MINOR "REVOLUTIONARY" SCHUMANN: PAPILLONS BEETHOVEN: SONATA NO.14 IN C-SHARP MINOR "MOONLIGHT" MUSSORGSKY: from PICTURES AT AN EXHIBITION XENAKIS: HERMA HANDEL: THE HARMONIOUS BLACKSMITH BACH: CHROMATIC FANTASIE AND FUGUE IN D MINOR, BWV903</p>	<p>Arthur MOREIRA-LIMA, piano (Steinway) András SCHIFF, piano (Steinway) John O'CONNOR, piano (Steinway) Takahiro SONODA, piano (Baldwin SD-10) Yuji TAKAHASHI, piano (Steinway) Zuzana RUZICKOVA, harpsichord (Ammer) Huguette DREYFUS, harpsichord (Shiftze)</p>
<p>OB-7346-7 (2 records set) —45 rpm—</p>		<p>THE BRILLIANT CONCERT FOR WIND VIRTUOSOS</p> <p>Siciliana-Sonata in E-Flat Major for Flute and Harpsichord BWV1031 (J. S. Bach)/Allegro-Sonata in G major for Flute and Harpsichord Obbligato, BWV1038 (J. S. Bach)/Fantasie No. 7 in D major for Flute solo (Telemann)/Air-"Il Pastor Fido" No.1 in C major (Vivaldi)/Allegro Un Poco-Sonata in D major for Flute and Harp (C. P. E. Bach)/Pavane Lachrymae theme and variations I-II-III (Van Eyck)/Sonata In G Minor for Oboe and Harpsichord Op. 1, No.6 (Handel)/Piri for Oboe solo-1971 (Isang Yun)/Allegro-Sonata in F minor for Fagott and Harpsichord (Telemann)/Wind Quintet in G minor Op.56, No.2 (Danzi)</p>	

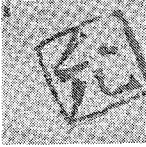
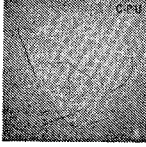

<p>OB-7348-9 (2 records set) —45 rpm—</p>		<p>THE BRILLIANT CONCERT FOR STRINGS Tzigane (Ravel)/Affetuoso'—Sonata No.4 in D major for Violin and Harpsichord, Op.1, No.13 (Handel)/Allegro Moderato-Sonata in B-flat major for Violin and Piano KV378 (Mozart) Caprice Viennoise, Op.2 (Kreisler)/Allegro-Concerto in G major for Viola and Strings (Telemann)/Vivace-Sonata in G minor for Viola da Gamba and Harpsichord, BWV1029 (J. S. Bach)/Hungarian Rhapsody, Op.68 (Popper)/Allegro Moderato-Serenade in E major for String Orchestra, Op.22 (Dvorak)/Valse-Serenade in C major for String Orchestra Op. 48 (Tchaikovsky)/Adagio For Strings, Op.11 (Barber)</p>	
<p>OB-7350-11 (2 records set)</p>		<p>SCHUBERT: SYMPHONY NO.9 IN C MAJOR "THE GREAT" (D.944) Recorded at Christuskirche, DDR/Berlin, June 11/13, 1978 Coproduced with VEB Deutsche Schallplatten DDR/Berlin</p>	<p>Heinz Rogner conducting BERLIN RADIO SYMPHONY ORCHESTRA</p>





OQ-7214~

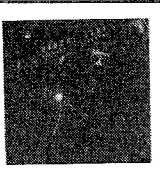
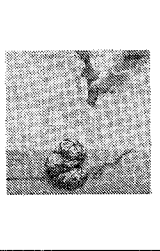

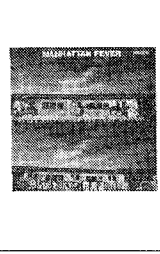
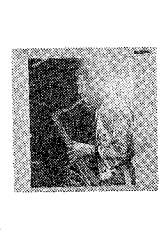
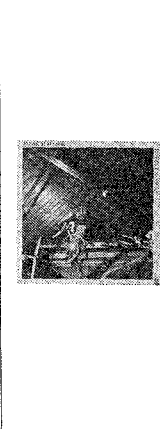



<p>OQ-7214 -21* (8 records boxed)</p>		<p>MOZART: THE COMPLETE PIANO SONATAS, RONDOS AND FANTASIES Grand Prix du Disque Académie du Disque Français, Paris Prix Edison de la Critique</p>	<p>Maria Joao PIRES, piano</p>
<p>OQ-7440 -2** (3 records boxed)</p>		<p>DVORAK: THE COMPLETE WORKS FOR PIANO, VIOLIN AND VIOLIN-CELLO Trio No.1 in B-Flat Major, Op.21 Trio No.2 in G Minor, Op.26 Trio No.3 in F Minor, Op.65 Trio No.4 in E Minor, Op.90 "Dumky" Recorded at Supraphon Domovina Studio, Praha</p>	<p>SUK TRIO</p>
<p>OQ-7443 -5** (3 records boxed)</p>		<p>MOZART: THE SIX HAYDN QUARTETS NO.14 IN G MAJOR, KV.387 NO.15 IN D MINOR, KV.421 NO.16 IN E-FLAT MAJOR, KV.428 NO.17 IN B-FLAT MAJOR, KV.458 "HUNTING" NO.18 IN A MAJOR, KV. 464 NO.19 IN C MAJOR, KV.465 "DISSONANCE"</p>	<p>SMETANA QUARTET</p>

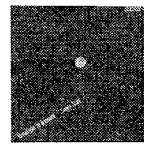

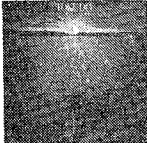

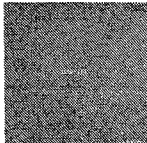

YX-7501		KWAN-JI-ZAI HAJIME MICHI KWAN-JI-ZAI ZIZOH-BOSATSU ZANMAI MUZIN Recorded on Apr. 13/14, 1976 in Tokyo	Masahiko SATO, solo piano
YX-7502		YUN PART I PART II Recorded on Mar. 3 & 30, 1976 in Tokyo	Masahiko SATO, solo piano
YX-7503		COSMIC PULSATION UNITY SEKIRAN A-UN Recorded on Dec. 10, 1975 in Tokyo	Masahiko TOGASHI, perc. Masahiko SATO, piano Keiki MIDORIKAWA, bass
YX-7504		GUILD FOR HUMAN MUSIC FIRST EXPRESSION SECOND EXPRESSION THIRD EXPRESSION FOURTH EXPRESSION FIFTH EXPRESSION SIXTH EXPRESSION Recorded on May 23/24 & 26/27, 1976 in Tokyo	Masahiko TOGASHI, comp./perc. Tatsuji YOKOYAMA, perc. Hideo MIYATA and Shojo NAKAGAWA, woodwinds Yoshio IKEDA, b. Keiki MIDORIKAWA, d., cello Masahiko SATO, keyboard
YX-7505		TWILIGHT/MASAHIKO TOGASHI & YUJI TAKAHASHI DAWN LI-HUN TWILIGHT	Yuji TAKAHASHI and Ryuichi SAKAMOTO, keyboard Masahiko TOGASHI and Yoshisaburo TOYOZUMI, perc.
YX-7506		ANTHONY BRAXTON/FOUR COMPOSITIONS Composition No. 1: Dedicated to Richard Teitelbaum Composition No. 2: Dedicated to Richard Abrams Composition No. 3: Dedicated to Warne Marsh Composition No. 4: Dedicated to Laurent Goddet Record on Jan. 11, 1973 in Tokyo	Anthony BRAXTON, ss. b-cl. s-cl. fl. as. Masahiko SATO, piano Keiki MIDORIKAWA, bass Hozumi TANAKA, perc.
YX-7507		SWING UP!! BLUE COATS PLAY BILLY STRAYHORN TAKE THE "A" TRAIN CHELSEA BRIDGE SNIBOR THE INTIMACY OF THE BLUES U. M. M. G. AFTER ALL ALL DAY LONG LOTUS BLOSSOM Recorded on Aug. 23/24, 1976 in Tokyo	Toshio MORI & BLUE COATS
YX-7511		PIANIC PIANISM STRAIGHT NO CHASER THE SUMMER KNOWS ECCENTRIC FUGUE STRAIGHT NO CHASER A MUDDY MUFFIN A FOOL ON THE HILL STRAIGHT NO CHASER MY ONE AND ONLY LOVE SKIP STEPS	Norio MAEDA, piano Masahiko SATO, piano Hiromasa SUZUKI, piano



<p>YX-7512</p>		<p>PIANIC PIANISM Vol. 2 —SUPER-TRI-PIANO— OVERTURE BRILLANTE ONCE I LOVED WILLOW WEEP FOR ME WALTZ FOR DEBBY AMEN FILTHY McNASTY FINAL CONFUSE</p>	<p>Norio MAEDA, piano Hiromasa SUZUKI, piano Masahiko SATO, piano</p>
<p>YX-7513</p>		<p>ESSENCE/TOGASHI'S GUILD FOR HUMAN MUSIC TURNING POINT MIRROR ANECDOTE ESSENCE DIRECTION OF THE WIND BONFIRE</p> <p>Recorded on Nov. 3→6, 1976 in Tokyo</p>	<p>Masahiko TOGASHI, percussion Shigeo SUZUKI, flute, sop. sax, altosax Masami NAKAGAWA, piano, percussion Masahiko SATOH, piano, percussion Keiki MIDORIKAWA, cello Yoshizaburo TOYOZUMI, percussion, marimba Katsuji YOKOYAMA, percussion Mieko TOGASHI, wine glass</p>
<p>YX-7514</p>		<p>MOTION WONDER BIRD PASSING BALLAD PLAYING BEAT</p> <p>Record on Jan. 30/31, 1977 in Tokyo</p>	<p>MASAHIKO TOGASHI TRIO Masahiko TOGASHI, percussion Masami NAKAGAWA, reeds and woodwinds Keiki MIDORIKAWA, bass</p>
<p>YX-7515</p>		<p>DANCE ALONG WITH BLUE COATS SENTIMENTAL JOURNEY JA-DA SUGAR BLUES SMOKE RINGS IT'S BEEN A LONG, LONG TIME STARDUST COCKTAILS FOR TWO SLEEPY TIME GAL EAST OF THE SUN SMOKE GET IN YOUR EYES</p> <p>Recorded on June 7 & Aug. 24, 1977 in Tokyo</p>	<p>Toshio MORI & BLUE COATS</p>
<p>YX-7516</p>		<p>SKETCH SKETCH 3 SKETCH 4 SKETCH 2 SKETCH 1</p> <p>Recorded on June 29→31, 1977 in Tokyo</p>	<p>MASAHIKO TOGASHI QUARTET</p>
<p>YX-7517</p>		<p>BLUES FOR POWELL CLEOPATRA'S DREAM ALL GOD'S CHILLUN GOT RHYTHM CHEROKEE SHAWNUFF STRIKE UP THE BAND ON A SLOW BOAT TO CHINA BODY AND SOUL BLUES FOR POWELL</p> <p>Recorded on Aug. 17 & 19, 1977 in Tokyo</p>	<p>EIICHI FUJII TRIO Eiichi FUJII, piano Kunimitsu INABA, bass Jun SHIMIZU, drums</p>

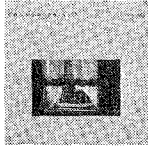



YX-7518		HIUCHI-ISHI RICHARD TEITELBAUM IN MEMORIAM H. M. KING WILLIAM'S TOWN	Richard TEITELBAUM , moogs Takashi KAKE piano and percussion Masami NAKAGAWA , alto sax and flute Masahiko TOGASHI , percussion
YX-7519		MASAHIKO TOGASHI VOICE FROM YONDER VOICE FROM YONDER SILENCE WELCOME TRAVELERS IT'S TIME FAREWELL Recorded on Feb. 2/3, 1978 in Tokyo	MASAHIKO TOGASHI QUARTET
YX-7520		HOT HOUSE BLUE COATS PLAYS TADD DAMERON TADD'S DELIGHT JUST PLAIN TALKIN' SOUL TRANE HOT HOUSE GOOD BAIT ON A MISTY NIGHT IF YOU COULD SEE ME NOW OUR DELIGHT	Toshio MORI & BLUE COATS
YX-7521		MANHATTAN FEVER THRUWAY TRAFFIC FOUR FIVE SIX MANHATTAN FEVER MARIE JEAN Recorded at Sound Ideas Studios, N. Y. C., November 29 & 30, 1977.	FRANK FOSTER AND THE LOUD MINORITY
YX-7522		SORAN-BUSHI, B. H BILLY HARPER TRYING TO GET READY LOVERHOOD SORAN-BUSHI, B. H Recorded at Sound Ideas Studios, N. Y. C., December 15 & 17, 1977	Billy HARPER (ts) E. HOLLINS (ts) H. MABERN (p) G. MAKER (b) H. ARNOLD (ds) B. HART (ds)
YX-7523		ALONE TOO LONG MUSIC FOR PIANO PARISIAN THOROUGHFARE IN YOUR OWN SWEET WAY LIKE A BUTTERFLY HERE'S THAT RAINY DAY ALONE TOO LONG MAYBE SEPTEMBER STROLLIN' BILLY HOLIDAY MEDLEY : GLAD TO BE UNHAPPY ~NO MORE~ THAT OLD DAVIL CALLED LOVE Recorded at Sound Ideas Studios, N. Y. C., December 8, 1977	Tommy FLANAGAN , piano solo

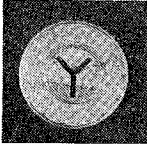

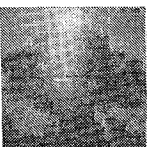
<p>YX-7524</p>		<p>ON GREEN DOLPHIN STREET ON GREEN DOLPHIN STREET ENOUGH THE SCENE IS CLEAN IN A MELLOW BLUES I THOUGHT ABOUT YOU</p> <p>Recorded at Sound Ideas Studios, N. Y. C., November 28, 1977</p>	<p>Archie SHEPP (ts & ss) W. BISHOP Jr. (p) S. JONES (b) J. CHAMBERS (ds)</p>
<p>YX-7525</p>		<p>LONESOME CAT KAZUMI WATANABE</p> <p>SOMEBODY SAMEBODY MIRRORS BLACK-STONE MOVING NOZZLE LONESOME CAT</p> <p>Recorded at Sound Ideas Studios, NYC on December 14, 1977</p>	<p>Kazumi WATANABE, guitar George CABLES, piano & electric piano Alex BLAKE, electric bass Cecil McBEE, bass Lenny WHITE, drums</p>
<p>YX-7526</p>		<p>LIGHTNING AND THUNDER BRIDGE WATER BROTHERS</p> <p>SILENT RAIN DEAR TRANE LIGHTNING AND THUNDER</p> <p>Recorded at Sound Ideas Studios, NTC on December 10, 1977</p>	<p>Cecil BRIDGEWATER, trumpet Ron BRIDGEWATER, tenor sax Stanley COWELL, piano Reggie WORKMAN, bass Michael CARVIN, drums</p>
<p>YX-7527</p>		<p>OUR MAN, PAPA JO!JO JONES</p> <p>TAKE THE "A" TRAIN/MY LAST AFFAIR STOMPIN' AT THE SAVOY/BROADWAY/ AS TIME GOES BY/WRAP YOUR TROUBLES IN DREAMS/SOLITUDE/IT DON'T MEAN A THING</p> <p>Recorded at Sound Ideas Studios, NYC., December 12, 1977</p>	<p>Jo JONES, drums Jimmy OLIVER, tenor sax Hank JONES, piano Major HOLLY, bass</p>
<p>YX-7528</p>		<p>ABIDE WITH ME/WALTER DAVIS</p> <p>ABIDE WITH ME/CROWDED ELEVATOR/ THEME FROM "LA STRADA"/BIRIBINYA NOS STATES/JUST ONE OF THOSE THINGS/PRANAYAMA/I'LL KEEP LOVING YOU</p> <p>Recorded at Sound Ideas Studios, NYC., November 22, 23 & December 1, 1977</p>	<p>Walter DAVIS, piano/Charles SULLIVAN, trumpet/Buster WILLIAMS, bass/Tony WILLIAMS, drums/NANA, percussion/Milton FRUSTINO, guitar/Carter JEFFERSON, tenor sax</p>
<p>YX-7530</p>		<p>MOONLIGHT IH VERMONT/SONNY STITT</p> <p>WEST 46 TH STREET/WHO CAN I TURN TO?/MOONLIGHT IN VERMONT/FLIGHT CAP BLUES/IT MIGHT AS WELL BE SPRING/CONSTELLATION/BLUES FOR PCM</p> <p>Recorded at Sound Ideas Studios, NYC, November 25, 1977</p>	<p>Sonny STITT, alto & tenor sax/ Barry HARRIS, piano/Reggie WORKMAN, bass/Tony WILLIAMS, drums/Walter DAVIS, piano</p>





YX-7531		<p>TOKUDO/BUSTER WILLIAMS TRIO TOKUDO/THIS TIME THE DREAM'S ON ME/FUEGO/THIS IS THE END OF A BEAUTIFUL FRIENDSHIP/SOMEDAY MY PRINCE WILL COME</p> <p>Recorded at Nippon Columbia's Studio, Tokyo, January 7, 1978</p>	<p>Buster WILLIAMS, bass/Kenny BARRON, piano/Ben RILEY, drums</p>
YX-7532		<p>DUET/ARCHIE SHEPP—DOLLAR BRAND FORTUNATO/BAREFOOT BOY FROM QUEENS TOWN/LEFT ALONE/THEME FROM "PROOF OF THE MAN"/UBU SUKU/MONIEBAH</p> <p>Recorded at Nippon Columbia's 1st Studio, Tokyo on June 5, 1978.</p>	<p>Archie SHEPP (ts & as & ss) Dollar BRAND (p)</p>
YX-7533		<p>LUSH LIFE/DAVE BURRELL In a Sentimental Mood*/Lush Life/Come Sunday*/Flower is a Loversome Thing/Mexico City*/Tradewinds/Crucifacade/Budapest Conclusion*</p> <p>Recorded at Nippon Columbia's 1st studio, Tokyo, April 2 & 3, '78</p>	<p>Dave BURRELL, piano Takashi MIZUHASHI, bass*</p>
YX-7534		<p>EARLY SUMMER IN TOKYO/TAKASHI MIZUHASHI AND HIS FRIENDS ISN'T SHE LOVELY/THE SHADOW OF YOUR SMILE/IN YOUR OWN SWEET WAY/O'GRANDE AMOR</p> <p>Recorded at Nippon Columbia's 1st Studio, Tokyo, on June 2, 12, 1978.</p>	<p>Takashi MIZUHASHI(b)/Archie SHEPP(ts & as)/Mickey TUCKER (p)/Horacee ARNOLD (ds)/Cecil BRIDGEWATER(tr)</p>
YX-7535		<p>SWEET LOTUS LIPS/MICKEY TUCKER TRIO GETTIN' THERE/RETURN TICKET/ALL OF YOU/SWEET LOTUS LIPS/AN AXE TO GRIND—A TREE TO CHOP/PORTRAIT OF A PEACEFUL SCENE</p> <p>Recorded at Nippon Columbia's 1st Studio, Tokyo, on June 3, 1978.</p>	<p>Mickey TUCKER(p) Reggie WORKMAN(b) Horacee ARNOLD(ds)</p>
YX-7536		<p>PAVAN LACHRYMAE/MASAHIKO SATOH GROM THE HIGHEST SPIRE/NO NIGHTS ARE DARK/ENOUGH/AND TEARS, AND SIGHTS, AND GROANS/MY WEARY DAYS/MY FORTUNE IS THROWN AND GRIEF, AND PAIN/LET ME LIVE FOR LORN</p>	<p>Masahiko SATOH, piano, electric piano synthesizers : KORG PS-3100 polyphonic : EMS Synthi AKS</p>
YX-7537		<p>ANTHEME FOR THE NEW NATIONS/DOLLAR BRAND ANTHEM FOR THE NEW NATIONS/BIRAL /LIBERATION DANCE/THE TRIAL/CAPE TOWN/THE WEDDING SUITE I) THE WEDDING, II) LOVERS, III) I SURRENDER, DEAR, IV) ONE DAY WHEN WE WERE YOUNG/THABA NCHU</p> <p>Recorded at Nippon Columbia's 1st Studio Tokyo, On June 10, 1978</p>	<p>Dollar BRAND, piano</p>





<p>YX-7538</p>		<p>LIVE IN TOKYO/ARCHIE SHEPP QUARTET CARAVAN/IN A SENTIMENTAL MOOD/ STEAM/STRAIGHT STREET</p> <p>Recorded Live at Nakano Sun Plaza Hall, Tokyo on June 6, 1978</p>	<p>Archie SHEPP, tenor & soprano sax Mickey TUCKER, piano Buster WILLIAMS, bass Horacee ARNOLD, drums</p>
<p>YX-7539</p>		<p>THE WORKS OF WORKMAN/REGGIE WORKMAN</p> <p>Visitation/I Can't Get Started/Take the "A" Train/Samba de Orfeu/Effie</p> <p>Recorded at Nippon Columbia's 1st studio, Tokyo, June 3, 10 & 12, '78</p>	<p>Reggie WORKMAN, bass solo</p>
<p>YX-7540</p>		<p>GON'S DELIGHT/TAKASHI MIZUHASHI AND HIS FRIENDS</p> <p>I Remember Clifford*/Dedicated to You*/ Oleo**/Summertime**</p> <p>Recorded at Nippon Columbia's 1st studio, Tokyo, June 2 & 12, '78</p>	<p>Takashi MIZUHASHI, bass Cecil BRIDGEWATER, trumpet* Mickey TUCKER, piano Horacee ARNOLD, drums Archie SHEPP, tenor saxophone**</p>
<p>YX-7541</p>		<p>'ROUND MIDNIGHT/DAVE BURRELL</p> <p>Straight, No Chaser*/'Round Midnight/Blue Monk*/Black Roberts/No Games*/New York</p> <p>Recorded at Nippon Columbia's 1st studio, Tokyo on April 2 & 3, '78</p>	<p>Dave BURRELL, piano Takashi MIZUHASHI, bass*</p>
<p>YX-7543</p>		<p>LADY BIRD/ARCHIE SHEPP QUARTET</p> <p>Donna Lee/Relaxin' at Camarillo/Now's the Time/Lady Bird/Flamingo</p> <p>Recorded at Sound Ideas Studio, New York N. Y., on December 7, 1978</p>	<p>Archie SHEPP, alto saxophone Jaki BYARD, piano Cecil McBEE, bass Roy HAYNEE, drums</p>
<p>YX-7544</p>		<p>TOGETHER/TOMMY FLANAGAN & KENNY BARRON</p> <p>Dig/If I Should Lose You/Stella by Starlight /I Can't Get Started/Darn That Dream/The Way You Look Tonight</p> <p>Recorded at Sound Ideas Studios, New York City, N. Y., December 6, 1978</p>	<p>Tommy FLANAGAN, piano (right side) Kenny BARRON, piano (left side)</p>
<p>YX-7545</p>		<p>SHINY STOCKINGS/FRANK FOSTER AND THE LOUD MINORITY</p> <p>Shiny Stockings Lovers Scene Tomorrow's Blues Today Dayspring Hills of the North Rejoice</p> <p>Recorded at Sound Ideas Studios, New York City, N. Y., November 22 & 28, 1978</p>	<p>Frank FOSTER, tenor & alto saxophone/Leroy BARTON Jr., Charles I. WILLIAMS, alto saxophone/Bill SAXTON, Bill CODY, Doug HARRIS, tenor saxophone/Kenny ROGERS, baritone saxophone/Emmet MACDONALD, Charles STEPHENS, Janice ROBINSON, trombone/Bill LOWE, bass trombone/Bill DAVIS, tuba/Sinclair ACEY, Virgil JONES, Joe GARDNER, Chris ALBERT, Robert RUTLEDGE, trumpet/Mickey TUCKER, piano/Ted DUNBAR, guitar/Earl MAY, bass & electric bass/Charli PERSIP, drums/ Babafumi AKUNYUN, percussion</p>





YX-7546		<p>MIDNIGHT OVER MEMPHIS/JOHN STUBBLEFIELD Iska Iska*** Midnight Over Memphis Mimi*,*** Cinnamon Showers Tomorrow's Friend*,**</p> <p>Recorded at Sound Ideas Studios, New York City N. Y., November 11 & 13, 1978</p>	<p>John STUBBLEFIELD II, soprano & tenor saxophone, percussion** /Oneje Allan GUMBS, piano, Rhodes piano, clavinet, mini moog/Fernando GUMBS, electric bass (higher), percussion**/Don PETE, electric bass (lower)***/Buddy WILLIAMS, drums/Steve THORNTON, congas & percussion And Special Guest: Eddie HARRIS, clavinet on "Mimi"</p>
YX-7547		<p>THE 24 TH STREET BAND Shoppin' 'Round Again/Down to the Waterfall/Don't Let Them Take You Away/ Full-Time Love/Pleasure Before Business/ Turn Your Heart to Stone/Quack!!!</p> <p>Recorded at Sound Ideas Studios, New York City, N. Y., December 13, 14 & 15, 1978</p>	<p>THE 24TH STREET BAND Hiram BULLOCK, Clifford CARTER, Steve JORDAN and Will LEE.</p>
YX-7548		<p>FANTASIA —Dedicated to Rasahn Roland Kirk— Hilton Ruiz/Swing One/Blues for Tommy Tucker/Fantasia</p> <p>Recorded at Sound Ideas Studio, New York City, N. Y., December 9, 1978</p>	<p>Hilton RUIZ, piano Slide HAMPTON, trombone Pharaoh SANDERS, tenor saxophone Reggie WORKMAN, bass Idris MUHAMMAD, drums</p>
YX-7549		<p>ESPECIALLY FOR YOU/ALEX BLAKE</p> <p>Recorded at Sound Ideas Studio, New York, Nov. 27, 29 & 30, 1978</p>	<p>Alex BLAKE, electric & acoustic bass, vocal Joe DELIA, keyboard Hiram BULLOCK, guitar Abe SPELLER, drums</p>
YX-7550		<p>NIGHT SONG/WALTER DAVIS TRIO Tempus Fugit/Night Song/Zany/Walter's Ballad/Seven of Swords/God Is Out Father</p> <p>Recorded at Sound Ideas Studio, New York City, N. Y., on Dec. 15, 1978</p>	<p>Walter DAVIS, piano, Tom BARNEY, bass Kenny WASHINGTON, drums</p>
YX-7801		<p>KNOWLEDGE OF SELF/BILLY HARPER</p> <p>Recorded at Sound Ideas Studio, NYC, Dec. 13, 1978</p>	<p>Billy HARPER, tenor saxophone Everett HOLLINS, trumpet Kenny BARRON, piano Gregg MAKER, bass Malcolm PINSON, drums</p>
YX-7802		<p>GENERATIONS SUITE/BRIDGEWATER BROTHERS African Sunrise/Bororo/Sade/Synapse/Your Ballad/Something I Saw Thro My Mind/ Samba Para Ustedos Dos</p> <p>Recorded at Sound Ideas Studio, N. Y. C., N. Y. on Dec. 1, 1978</p>	<p>Cecil BRIDGEWATER(tp, flh) Ron BRIDGEWATER(ts, ss, fl) Hubert EAVES(p, kalimba) Donald SMITH(el-p, fl) Reggie WORKMAN(b, perc) Michael CARVIN(ds)</p>

<p>YX-7803</p>		<p>PUNJAB/JOE CHAMBERS PLAYS PIANO Punjab/The Scene Is Clean/Joe's Blues/ Spring Is Here/Darkness/Nica's Dream/ Caravanessa</p> <p>Recorded at Sound Ideas Studio, N. Y. C., N. Y., on Dec. 8, 1978</p>	<p>Joe CHAMBERS, piano solo</p>
<p>YX-7804</p>		<p>THEME FOR A WOOGIE-BOOGIE/MICKEY TUCKER Theme For A Woogie-Boogie/Kap'n Kryptonite/A Tribute To Bean/Japanese Soundscape/Bogue Ballad Bossa</p> <p>Recorded at Sound Ideas Studio, N. Y. C., N. Y., on Nov. 15 & 16, 1978</p>	<p>Mickey TUCKER, piano Louis SMITH, trumpet Curtis FULLER, trombone Jimmy BUFFINGTON, french horn Takashi "Gon" MIZUHASHI, bass Eddie GLADDEN, drums</p>
<p>YX-7805</p>		<p>CONVERSATION/REGGIE WORKMAN FIRST Mark II/Deja Vu/Conversation</p> <p>Recorded at Sound Ideas Studio N. Y. C., N. Y., on Dec. 19, 1977</p>	<p>Reggie WORKMAN, bass, Cecil BRIDGEWATER, trumpet, Slide HAMPTON, trombone, George ADAMS, tenor saxophone, Albert DAILEY, piano, Michael CARVIN, drums, Lawrence KILLIAN, percussion</p>
<p>YX-7806</p>		<p>TRAY OF SILVER/ARCHIE SHEPP No Smokin'/If You Could See Me Now/ Nica's Dream/Cookin' At The Continental</p> <p>Recorded at Nippon Columbia's 1st Studio Tokyo, on Apr. 11, 1979</p>	<p>Archie SHEPP, tenor saxophone Mickey TUCKER, piano Takashi "Gon" MIZUHASHI, bass Roy BROOKS, drums</p>
<p>YX-7807</p>		<p>MORITAT —Eiichi Fujii Plays Sonny Rollins— Moritat/Tenor Madness/Doxy/Oleo/St. Thomas/Airegin/Way Out West/Sonny moon For Two/The Bridge</p> <p>Recorded at Nippon Columbia's 1st Studio on August 8, 9, 10, 1979</p>	<p>EIICHI FUJII TRIO: Eiichi FUJII(p) Satoshi KOSUGI(b) Fumio WATANABE(ds)</p>



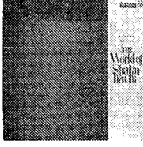

YX-7262		PCM/BLUE ARANJUEZ Blue Aranjuez/Melancholic Waltz/Autumn Concerto/To Love Again/White Sicilienne/Fantaisie-Impromptu/Pathetique Sonata/Farewell Song Recorded at Nippon Columbia No. 1 Studio on Jan. 24 & 25, 1980.	TERRY HERMAN TRIO
YX-7277		ANOTHER SOIL All Green Have You Met Mr. Jones Double Peace Zubrowka Freak Another Soil	Tomoki TAKAHASHI (ts, ss). Junichiro OHGUCHI (p) Hideaki MOCHIZUKI (b) Tamio KAWABATA (b) Shigeharu MUKAI (tb) Elvin JONES (ds) Kiyoshi SUGIMOTO (g)





<p>SX-7001</p>		<p>BEST OF SCREEN MUSIC LOVE STORY LOVE THEME FROM "THE GODFATHER" SOME ENCHANTED EVENING LARA'S THEME AROUND THE WORLD MELODIE EN SOUS-SOL TREIZE JOURS EN FRANCE PLEIN SOLEIL THEME DE LA LEÇON PARTICULIERE IL FERROVIERE FROM RUSSIA WITH LOVE</p>	<p>COLUMBIA MILION POP OR- CHESTRA</p>
<p>SX-7002</p>		<p>LA MACARENA CUBAN ROCK SOUNDS TABU/HISTORIA DE UN AMOR SIBONEY/ QUIEN SERA/LA MACARENA/BABALU/ BESAME MUCHO/LA CANCION DE ORFE/ ESTRELLITA/PERFIDIA/EL MANICERO</p>	<p>T. MISAGO & HIS TOKYO CUBAN BOYS</p>
<p>SX-7003</p>		<p>LATIN PERCUSSION HISTORIA DE UN AMOR/ LA VIRGEN DE LA MACARENA/TICO TICO/BESAME MUCHO/LA BAMBA/GUANTANA MERA/ BABALU/MARIA ELENA/ANNA/ADIOS MARIQUITA LINDA</p>	<p>Y. SEGAMI & HIS EXCITING COMPANY</p>
<p>SX-7004</p>		<p>INVITATION TO THE POP CLASSICAL MUSIC-1 BEETHOVEN: 9th SYMPHONY MOV. IV BRAHMS: HUNGARIAN DAMCE NO.5 BIZET: MUSIC FROM "CARMEN" MOZART: MUSIC FROM "LE NOZZE DI FIGARO" CHOPIN: NOCTURNE OP.9-2 VIVALDI: THE SPRING FROM "FOUR SEASONS" TCHAIKOVSKY: PIANO CONCERTO MOV.I DEBUSSY: CLAIR DE LUNE VERDI: ANVIL CHORUS RACHMANINOV: PIAON CONCERTO NO.2 WAGNER: MUSIC FROM "DIE MEISTER- SINGER VON NURNBERG" BORODIN: POLOVTSIAN DANCE</p>	<p>DIE FLEDERMAUS</p>
<p>SX-7005</p>		<p>INVITATION TO THE POP CLASSICAL MUSIC-2 DVORAK: HOME COMMMING FROM THE NEW WORLD SYMPHONY SCHUBERT: SERENADE J. STRAUSS: DIE FLEDERMAUS BACH: AIR ON G STRINGS WEBER: MUSIC FROM "DER FREISHUTZ" LISZT: HUNGARIAN RHAPSODY NO.2 ROSSINI: IL BARBIERE DI SEVIGLIA- OVERTURE MENDELSSOHN: VIOLIN CONCERTO GRIEG: ANITRA'S DANCE FROM "PEER GYNT" SCHUMANN: TRAUMEREI RAVEL: BOLERO MOUSSORGSKY: FROM "PICTURES AT AN EXHIBITION"</p>	<p>DIE FLEDERMAUS</p>



SX-7006		<p>JOHN WILLIAMS WORKS</p> <p>Theme from "Superman"/Theme from "Close Encounters of the Third Kind"/Theme from "Jaws 2"/Star Wars-MAIN TITLE-/Theme from "Black Sunday"/Midway March/The Fury-MAIN TITLE-/I Want to Spend my Life with You/Earthquake-MAIN TITLE-/Theme from the Eiger Sanction/Cinderella Liberty Love Theme</p> <p>Recorded at NIPPON COLUMBIA GRAND STUDIO, Tokyo</p>	<p>THE CROAD TERRY GRAND ORCHESTRA</p>
SX-7007		<p>SCREEN MUSIC FOR LOVERS —Music from the Motion Picture—</p> <p>Love Story (Where Do I Begin)/Evergreen (Love Theme from "A Star Is Born")/The Sound of Silence/St. Michel Theme from "Last Concert"/It's Time to Say I Love You (Love Theme from "The Other Side of The Mountain Part 2")/The Way We Were/A Time for Us (Love Theme from "Romeo and Juliet")/Theme de la Leçon Particulere/Friends/Sunflower/A Man and a Woman/Live for Life</p> <p>Record at NIPPON COLUMBIA GRAND STUDIO, Tokyo</p>	<p>THE CROAD TERRY GRAND ORCHESTRA</p>
SX-7008		<p>BELOVED SCREEN MUSIC —Music from the Motion Picture—</p> <p>Over the Rainbow/Gonna Fly Now (Theme from "Rocky")/Speak Softly Love (Love Theme from "The Godfather")/Ben-Hur Love Theme/Raindrops Keep Fallin' on my Head/Summertime in Venice/Theme from "East of Eden"/Tara's Theme/From Russia With Love/Plein Soleil/Love Is a Many-Splendored Thing</p> <p>Recorded at NIPPON COLUMBIA GRAND STUDIO, Tokyo</p>	<p>THE JUN NOERSIAH STRINGS</p>
SX-7009		<p>A&BA THE BIG BAND</p> <p>Dancing Queen/Eagle/Money, Money, Money/I Do, I Do, I Do, I Do, I Do/Waterloo/Chiquitita/That's Me/I Am Just a Girl/Thank You For The Music/Hasta Manana</p>	<p>TOSHIO MORI & BLUE COATS</p>
SX-7010		<p>GRAMMY WINNERS —Love Sound Fashion—</p> <p>Copacabana (At The Copa)/Just The Way You Are/Hotel California/Killing Me Softly With His Song/I Honestly Love You/This Masquerade/You Light Up My Life/Love Will Keep Us Together/The First Time Ever I Saw Your Face/You've Got A friend</p>	<p>SHOJI YOKOUHI QUARTET SYMPHONIC FUSION</p>
SX-7011		<p>SCREEN REPORT VOL.1</p> <p>Love Theme From Death On the Nile/Don't Ask To Stay Until Tomorrow/Heaven Can Wait/Convoy/Love Song/Theme From "SUPERMAN"/Nobody Does It Better/Good-bye Girl/Love Theme From "OLIVER'S STORY"/How Deep Is Your Love/You Light Up My Life</p>	<p>THE CROAD TERRY GRAND ORCHESTRA</p>

<p>WP-7005</p>		<p>THE WORLD OF SHAMISEN KANJIN-CHO YANAGI NO KIYARI TSUGARU JONGARA-BUSHI FUKAGAWA-BUSHI KAPPORE ECHIGO-JISHI GENROKU HANAMI-ODORI KITSUNEBI IYA NO KOBIKI-UTA YAKKO-SAN KYOKANOKO MUSUME DOJOJI</p>	<p>Isoshichi YOSHIMURA, Seiji TSURUSAWA, Kimio SUGAWARA, Toyohisa, Shizuko and Hidetaro HONJO, shamisens</p>
<p>WP-7006</p>		<p>THE WORLD OF FUE NOKAN JOKYOKU KUROKAMI AZEMICHI SHINOBU DOKUSO KYOKU MATSURI MATSURI MATSURI UTAGE NOKAN KYUKYOKU KIYARI KUZUSHI GION KOUTA KOKIRIKO-BUSHI UME NO UTA-GENKA GRIEG: THE MORNING from "PEER GYNT"</p>	<p>Yoshio NAKAGAWA, fue</p>
<p>WP-7007</p>		<p>THE WORLD OF TSUZUMI CHOYO CONVERSATION BETWEEN BIWA AND KO-TSUZUMI CONVERSATION BETWEEN JAPANESE PERCUSSIONS AND KO-TSUZUMI CONVERSATION BETWEEN SUKEROKU-DRUM AND KO-TSUZUMI FOUR BEATS OEDO NIHON-BASHI YAMADERA NO OSHOSAN CUMANA TAKE FIVE KHACHATURIAN: SABRE DANCE from GAYNE</p>	<p>Kisaku KATADA, tsuzumi</p>
<p>WP-7008</p>		<p>THE WORLD OF SHAKUHACHI SOKAKU REIBO SHIKA NO TONE KOKU REIBO ZANGETSU TAKIOCHI NO KYOKU ESASHI OIWAKE Part 1 TSUGARU YAMA-UTA MOGAMI-GAWA FUNA-UTA NAMBU USHIOI-UTA ITSUKI NO KOMORI-UTA ESASHI-OIWAKE Part 2</p>	<p>Gor YAMAGUCHI and Isamu YASHITA, shakuhachis</p>
<p>WP-7009</p>		<p>THE WORLD OF SO (KOTO) ROKUDAN CHIDORI NO KYOKU MIDARE YACHIYO JISHI AKI NO KOTO NO HA SAKURA SAKURA IMAYO TORYANSE ZUI ZUI ZUKKOROBASHI DEBUSSY: CLAIR DE LUNE</p>	<p>Toshiko YONEKAWA, so</p>



WX-7501		<p>DAN TSUGARU JONGARA-BUSHI TSUGARU YOSARE-BUSHI TSUGARU SAN-SAGARI TSUGARU OHARA-BUSHI TSUGARU AIYA-BUSHI YOSABURO-BUSHI TSUGARU JINKU~JUSAN NO SUNAYAMA~KUROISHI~YOSADE-BUSHI~ RINGO-BUSHI</p>	<p>Katsuaki SAWADA, Kimio SUGAHARA, Shujiro TAKAHASHI, tsugaru shamisen Jiro FUKUDA, shakuhachi</p>
WX-7502		<p>HIBIKI/JAPANESE DRUMS SUWA MIHASHIRA KIYARI --HIRYU SANDAN GAESHI YUKI OROSHI--SUWA-RAI DRUMS OF SUWA GION DRUMS OF FESTIVAL IN TOKYO DRUMS OF SADO MUSIC OF CHICHIBU FESTIVAL DRUMS OF YOSE</p>	
WX-7503		<p>OSORE-SAN JONGARA NO SATO</p>	<p>Masako HIRAYAMA, biwa Naoki KORIKAWA, shakuhachi Yonosuke SEGAMI, Akira HAYASHI and Kenzo HATANAKA, Japanese drums Katsuaki SAWADA, shamisen Kifu MITSUHASHI, shakuhachi Kiyoshi YAMAYA conducting CONTEMPORARY SOUND ORCHESTRA</p>
WX-7506		<p>THE WORLD KOMUSO FUKE JOBUTSU MAROBASHI-SUGA-GASA REIBO MU-KAI-JI</p>	<p>Kifu MITSUHASHI, shakuhachi Kiyoshi YAMAYA conducting CONTEMPORARY SOUND ORCHESTRA</p>
WX-7507		<p>THE WORLD OF GIDAYU-SHAMISEN SHIKI (FOUR SEASONS) MANZAI~AMA~SEKIDERA~KOMACHI~ SAGI-MUSUME KITSUNEBI HORIKAWA SARU-MAWASHI</p>	<p>Seiji TSURUSAWA, shamisen Kiyoshi YAMAYA conducting CONTEMPORARY SOUND ORCHESTRA</p>
WX-7508		<p>SHINO-BUE PLAYS DEBUSSY THE CHILDREN'S CORNER REVERIE CLAIR DE LUNE</p>	<p>Yoshio NAKAGAWA, shinobue Kiyoshi YAMAYA conducting CONTEMPORARY SOUND ORCHESTRA</p>
WX-7509		<p>TORU TAKEMITSU: NOVEMBER STEPS KINSHI TSURUTA: SUMA NO URA</p>	<p>Kinshi TSURUTA, biwa</p>
WX-7510		<p>MIYABI TRADITIONAL KOTO MUSIC HANAYAGI MIDARE ROKUDAN SHIN-YACHIYO JISHI</p>	<p>Keiko NOSAKA, koto JAPANESE INSTRUMENTAL ENSEMBLE</p>

<p>WX-7511</p>		<p>CHANSON FRANÇAISE ON KOTO LES FEUILLES MORTE, HYMN À L'AMOUR LA VIE EN ROSE, TU NE SAIS PAS AIMER SOUS LE CIEL DE PARIS, LA MER MADEMOISELLE DE PARIS MON COEUR EST UN VIOLON, MÉLANCOLIE, L'ÂME DES POÈTES, LES LILAS, CHARMAINE</p>	<p>Toshiko YONEKAWA, Hiroe YONEKAWA and Masumi YONEKAWA, kotos Chikatoyo TSUJIMOTO jushichigen</p>
<p>WX-7512</p>		<p>CLASSICAL FAVORITES ON KOTO, FUE and SHAMISEN FALLA: DANSE RITUELLE DU FEU, LISZT: LIEBESTRAUM RAVEL: PAVANE POUR UNE INFANTE DÉFUNTE, KETELBY: IN A PERSIAN MARKET, MASSENT: THAÏS MEDITATION, KHACHATURIAN: SABRE DANCE, MASSENET: ÉLÉGIE, BORODIN: POLOVETZER TÄNZE, MASCANI: CAVALLERIA RUSTICANA, PONCHIELLI: DAECE OF THE HOURS from "La Gioconda", CHOPIN: ETUDE OP.10-3</p>	<p>Toshiko YONEKAWA, koto Yoshio NAKAGAWA, fue Kifu MITUHASHI, shakuhachi Kisaku KATADA, thuzumi and others</p>
<p>WX-7513</p>		<p>VIVALDI: FOUR SEASONS ON KOTO FUE and SHAKUHACHI</p>	<p>Toshiko YONEKAWA, Hiroe YONEKAWA and Masumi YONEKAWA, kotos Chikatoyo TSUJIMOTO, jushichigen Yoshio NAKAGAWA, fue Kifu Mitsunashi, shakuhachi</p>
<p>WX-7514</p>		<p>SHAMISEN Japanese traditional sound —HOSOZAO— KABUKI (DANMARI), OZATSUMA, MATSURI, KURUWA, MUSHI, KANJINCHO —FUTOZAO— MERIYASU, MICHYUKI, KITSUNEBI, SHIKI, NOZAKI</p>	<p>Isoshichi YOSHIMURA, Kikujiro OKAYASU, Chyugoro MATSUNAGA, Kikusaburo OKAYASU, Seiji TSURUSAWA, Seisuke TSURUSAWA, shamisens Tahachi MOCHIZUKI, fue Kisaku KATADA, narimono</p>
<p>WX-7515</p>		<p>SHAKUHACHI Japanese traditional sound SHIKA NO TONE AKITA SUGAGAKI TSURU NO SUGOMORI~SOKAKU REIBO</p>	<p>Goro YAMAGUCHI, Reibo AOKI, Shakuhachi</p>



WX-7516		SO (KOTO) ~The World of Tadao Sawai~ KAGERO CHIDORI NO KYOKU From CHIISA NA HARU GODAN KINUTA RADEN ROKUDAN	
WX-7517		HOGAKU HAYASHI NO MIRYOKU RANRYO NO MAI	
WX-7518		INVITATION TO JAPANESE TRADITIONAL MUSIC DANMARI KANJIN CHO KITSUNE BI OHKAWA BATA ASATOYA YUNTA MATSURI MATSURI MATSURI ROKUDAN SOKAKU REIBO KUROKAMI SUKEROKU DAIKO TO KOZUTSUMI NO OHANASHI YON BYOSHI	
WX-7519		SO (KOTO) MIDARE YOMIGAERU ITSUTU NO UTA CHIKURAI ARUMA NO KUMO	
WX-7520		ZEN SHAKUHACHI SHINMU KAIJI TORI MONZUKE HACHI KAESHI YOBITAKE UKETAKE SHIKA NO TONE	

ZX-7018		<p>KALYANI ROY THE VIRTUOSO OF SITAR-1 RAGA: TODI DURGA MISHRA KAMAJ</p> <p>Recorded in Sept. 1975 in Tokyo</p>	<p>Manick DAS, tabla Namita CHATTERJEE, tambura</p>
ZX-7019		<p>KALYANI ROY THE VIRTUOSO OF SITAR-2 RAGA: YAMAN YAMAN (GAT II) BHITALI (Boatsong of Bengal)</p> <p>Recorded in Sept. 1975 in Tokyo</p>	<p>Manick DAS, tabla Namita CHATTERJEE, tambura</p>
ZX-7020		<p>M. NAGESWARA THE VIRTUOSO OF VEENA KRITI: JANAKI RAMANA NIVADA NEGNA PAKKALA NILABADI TILLANA: THA DHIM DHIM TA</p> <p>Recorded in Oct. 1976 in Tokyo</p>	

GX-7027

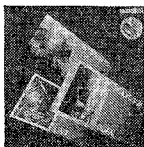
GX-7027		<p>ROOTS! AFRICAN DRUMS TAKACHINJA (For Hunting) MALEPENENGA (Impromptu) MOYONGA (The Dance of Trees) HEVIUMA (Girls' Dance in Love) JENJELA RUNYENJE (The Dance After a Work)</p> <p>Recorded in Aug. 1977 in Tokyo</p>	<p>KENYA NATIONAL DANCING TEAM</p>
GX-7108		<p>BALACHANDER THE VIRTUOSO OF VEEMA —Classical Music of South India— RAGAM CHAKRAVAAKAM</p>	<p>M. A. EASWARAN, mridangam T. H. VINAYAKRAM, gatam</p>

ST-6007		<p>INVITATION TO DENON/PCM DIGITAL CLASSICS</p> <ul style="list-style-type: none"> *Pictures at an Exhibition (Mussorgsky) Louis FREMAUX conducting TOKYO METROPOLITAN SYMPHONY ORCHESTRA (from OX-7072) *Tocatta and Fugue in D Minor, BWV 565 (J.S. Bach) Helmuth RILLING, organ (from OX-7027) *Symphony No. 9 in D Minor, Op. 125 "Choral" (Beethoven) Vaclav NEUMANN conducting CZECH PHILHARMONIC ORCHESTRA (from OB-7333/4) *Adagio in G Minor for Strings and Organ (Alibonini—arr. Giazotta) Jorgen Ernst HANSEN conducting SOCIETAS MUSICA CHAMBER ORCHESTRA (from OX-7061) *Choral "Jesus Bleibet Meine Freude" BWV 147 (J.S. Bach) Knud VAD, organ (from OX-7048) *Trio Sonata in D Minor—3rd Movement: Allegro (C. P. E. Bach) Jean—Pierre RAMPAL, Maxence LARRIEU, flutes (from OX-7006) *Symphony No. 36 in C Major KV 425 "Linz" (Mozart) Otmar SUTNER conducting THE NHK SYMPHONY ORCHESTRA (from OX-7156) *Symphony No. 9 in C Major "The Great" (Schubert) Heinz ROGNER conducting BERLIN RADIO SYMPHONY ORCHESTRA (from OB-7350/1) *Farandole—L'Arlesienne Suite No. 2 (Bizet) Reiner MIEDEL conducting YOMIURI NIPPON SYMPHONY ORCHESTRA (from OX-7153) *Divertimento in D Major KV 136—2nd Movement: Andante (Mozart) Vassil KASANDJIEV conducting SOFIA CHAMBER ORCHESTRA (from OX-7146) *Fille Aux Cheveaux De Lin (Debussy) Ayako SHINOZAKI, harp (from OX-7133) *Symphony No. 4 in F Major Op. 36 (Tchaikovsky) Kurt SANDERLING conducting BERLIN SYMPHONY ORCHESTRA (from OX-7137)
ST-6008		<p>INVITATION TO DENON/PCM DIGITAL JAZZ</p> <ul style="list-style-type: none"> *FOUR FIVE SIX (Frank Foster) from the album "Manhattan Fever" (YX-7521) Frank Foster and the Loud Minority *SORAN—BUSHI, B. H. (Billy Harper) from the album "Soran-bushi, B. H." (YX-7522) Billy Harper *PARISIAN THOROUGHFARE (Bud Powell) from the album "Alone Too Long" (YX-7523) Tommy Flanagan *ON GREEN DOLPHIN STREET (Kaper—Washington) from the album "On Green Dolphin Street" (YX-7524) Archie Shepp *TAKE THE "A" TRAIN (Billy Strayhorn) from the album "Our Man, Papa Jo!" (YX-7527) Jo Jones *CONSTELLATION (Charlie Parker) from the album "Moonlight In Vermont" (YX-7530) Sonny Stitt *IN A SENTIMENTAL MOOD (Ellington—Tizoi) from the album "Live In Tokyo" (YX-7538) Archie Shepp *DONNA LEE (Charlie Parker) from the album "Lady Bird" (YX-7543) Archie Shepp *LUSH LIFE (Strayhorn) from the album "Lush Life" (YX-7533) Dave Burrell *DIG (Miles Davis) from the album "Together" (YX-7544) Tommy Flanagan & Kenny Barron *SHINY STOCKINGS (Frank Foster) from the album "Shiny Stockings" (YX-7545) Frank Foster and the Loud Minority *Excerpt from GENERATION SUITE (Bridgewater) from the album "Generation Snite" (YX-7802) Bridgewater Brothers *TEMPUS FUGIT (Bud Powell) from the album "Night Song" (YX-7550) Walter Davis *IF YOU COULD SEE ME NOW (Tadd Dameron) from the album "Tray of Silver" (YX-7806) Archie Shepp

<p>OW-7403</p>		<p>DENON/PCM 45 rpm Audio Technical Series 1 TRACKING ABILITY HEARING TEST PROGRAMS FOR DISC CARTRIDGE</p> <ol style="list-style-type: none"> 1. ORCHESTRA—Tchaikovsky : Symphony No. 4 2. VIOLIN—Tchaikovsky : Violin Concerto 3. CELLO—Popper : Hungarian Rhapsody 4. PIANO—Schumann : Papillons Op. 2 5. HARP—Debussy : La fille aux cheveux de lin 6. SAXOPHON—R. Bridgewater : Dear Train 7. DRUMS—trad : Calvary
<p>OW-7404</p>		<p>DENON/PCM 45 rpm Audio Technical Series 2 PROGRAMS FOR COMPARATIVE TEST OF SOUND QUALITY</p> <ol style="list-style-type: none"> 1. ORCHESTRA—Tchaikovsky : Symphony No. 4 2. STRING QUARTET—Beethoven : Op. 18 No. 1 3. VIOLIN—Tchaikovsky : Violin Concerto 4. CELLO—Popper : Hungarian Rhapsody 5. DOUBLE-BASS—Simon Marks : All of Me 6. PIANO—Schumann : Papillons, Op. 2 7. HARP—Debussy : La fille aux cheveux de lin 8. FLUTE—J. S. Bach : Partita, BWV. 1020 9. SAXOPHON—R. Bridgewater : Dear Train 10. TRUMPET—Telemann : Marches Heroiques (Gabel) 11. VOCAL—Schumann : Liederkreis, Op. 39 12. DRUMS—trad : Calvary 13. ORCHESTRA—Tchaikovsky : Symphony No. 4 14. JAZZ COMBO—Strayhorn : Take the "A" Train 15. CROSS OVER MUSIC ENSEMBLE—Watanabe : Black Stone 16. ORGAN—J. S. Bach : Prelude & Fugue BWV. 548 17. HARPSICHORD—F. Couperin : Les Fastes de la ancienne Mxnstrxndxsx

**AUDIO TECHNICAL TEST RECORDS
FOR PROFESSIONAL USE
(Regular Stereo Recordings)**

REMARKABLE FEATURES OF THIS NEW SERIES

1.3 Hz—50 KHz sweep test, using only one record.
2.Can be used with any equipment corresponding to JIS (Japanese Industrial Standard) or DIN (Deutsche Industrie—Norm).
3.To be cut by using cutting lathe of less than 0.008% deviation in rotation speed except each B side of XG 7003 and XG 7004.
4.Spot-signal source reliability to $\pm 5 \times 10^{-6}$ except each B side of XG 7003, 7004 and 7005.

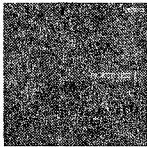
XG-7002		<p>PICK-UP TEST I</p> <p>Very High Frequency Sweep 1 KHz—50 KHz Very Low Frequency Sweep 3 Hz—1 KHz</p>
----------------	---	--

This record is for testing frequency response, and crosstalk characteristics of pick-up including tone arm from ultra-high to ultra-low frequencies.

Ultra-low frequency sweep signals (3 Hz—1 KHz) and ultra-high frequency sweep signals (1 KHz—50 KHz) are recorded on the same side.

Ultra-low & ultra-high frequency characteristics can be recorded by a B & K TYPE 2305 or TYPE 2307 level recorder and by combining the recorded data it is possible to determine the characteristics over a wide band from 3 Hz—50 KHz.

A & B sides have the same contents.

XG-7003		<p>PICK-UP TEST II</p> <p>Mechanical Impedance Measurements Reference Level Polarity Test</p>
----------------	---	--

On the A side sine waves for testing mechanical impedance, which is the basic performance of a cartridge, are recorded. Thus this record is essential for research and development for cartridges.

The B side bears recordings of 1 KHz standard signals to check cartridge output voltage and crosstalk, and square waves for polarity checking, and will be extremely useful for Quality Control, research & development and design.

Two kinds of basic standard signals, DIN and JIS, are recorded.

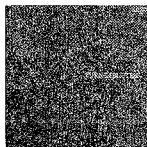
XG-7004		<p>TURNTABLE TEST</p> <p>Wow & Flutter Measurements Rumble Measurements</p>
----------------	---	--

On the A side 3 KHz and 3.15 KHz sine waves for testing wow and flutter and rotating accuracy are recorded at high frequency accuracy so that these characteristics may be tested for corresponding to JIS, DIN, NAB etc. standards.

The same signal is recorded in the outside, middle and inside grooves. Thus this record is highly suitable for Quality Control for low cost players which tend to be affected by pick-up load in respect to rotation errors.

On the B side is recorded the DIN 315 Hz 5.42 cm/S standard signal and there is also non modulated groove to test the Rumble-noise of the turntable.

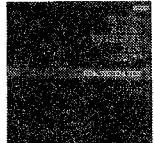
XG-7005		RIAA SYSTEM TEST Sweep Frequency 20 Hz—20 KHz Spot Frequency 1/3 Octave Band Noise
---------	---	--

This record is produced to measure frequency response, crosstalk characteristics and distortion of a sound reproducing system throughout cartridge, tone arm, RIAA reproducing equalizer amplifier. Thus we provide all round testing capability on one record.

The record can also test transmission characteristics of speakers, listening rooms and halls.

On the A side are recorded the RIAA-equalizing characteristics sweep signal (20 Hz—20 KHz) and spot signal and on B side 1/3—octave band noise and D. S. B. C. Linear Weighting characteristic pink noise.

The sweep signal and the 1/3 octave band noise recorded on this record are synchronized to the B & K 2305 and 2307 level recorders.

A MAGNIFICENT NEW RECORDING SYSTEM.



The Improved DENON PCM (Pulse-Code Modulation) Recording System (DN-034R)

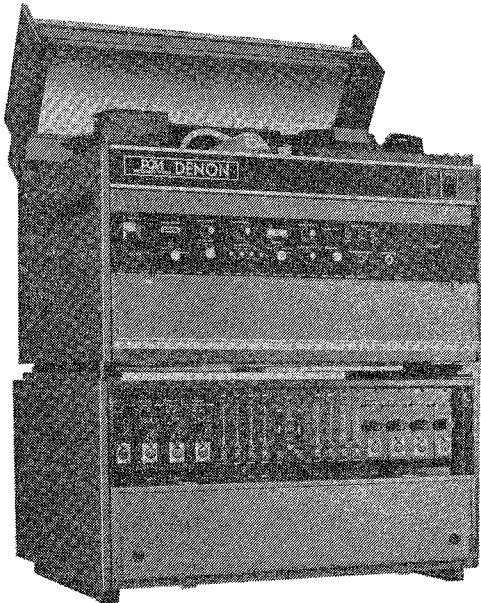

FEATURES

- Wide dynamic range (more than 89 dB in practical use).
- Low distortion factor (less than 0.1% at operating level).
- No wow and flutter (not measurable).
- No crosstalk.
- A flat frequency response over the wide range (DC-19kHz ± 0.2 dB, DC-20kHz +0.2 -1.0dB).
- Multi-channel recording and reproduction (8,4 and 2 channels).
- An ordinary VTR is used as the recorder.
- Synchronized recording with two VTRs.
- High Quality duplication with two VTRs.
- Editing and splicing.
- No ghosts; recordings can be stored for long periods of time.

DESCRIPTION

Introduction

Professional sound recording requires a recorder with uniform input and output signals. This compares with an ordinary tape recorder which records music waveforms on tape as analog variations in magnetic force and which displays a slight difference in tone quality between the input and output signals. Various experiments have been conducted in an attempt to minimize this difference.

Conventional tape recorders using proportional magnetization are far from ideal because of the nonlinear distortion, noise, modulation noise and other adverse factors caused by the tape itself and tape transport fluctuations. Although it is becoming increasingly difficult to achieve further improvements in this area, there is fortunately an entirely different method which solves all the problems. It is called the Pulse-Code Modulation (PCM) method, and it is being actively adopted for computers, space communications, telephone system and others, because it can transmit a great deal of information accurately under restrictive conditions. Fig. 1 shows the difference between PCM and conventional recording methods.

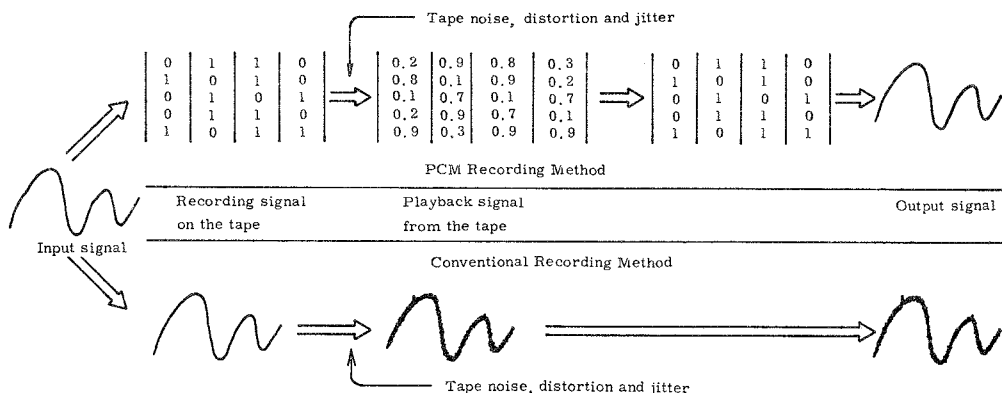

Fig. 1 The difference between PCM and conventional recording methods

PCM Recording

Under the PCM method, music waveforms are not directly recorded on tape as with ordinary tape recorders but are converted into a pulse code. This is then recorded onto a magnetic tape or other device. For reproduction, the code is reconverted into the original music waveforms by synchronizing the recordings with a reference signal so that the playback time domain will be the same as for the original recording. Any errors in the code are detected and corrected. Since the tape is recorded using only a train of pulses, there is no distortion or noise attributable to the tape.

However, the PCM method needs such a wide range of frequencies that a video tape recorder or an other wide-band recorder must be used for recording.

The first PCM recording system (DN-023R) for studio use and a portable PCM recording system (DN-023RA) were developed by Nippon Columbia in 1972 and 1974, respectively. These systems were used by the company for recording sessions in studios, halls and churches to manufacture more than 150 disc titles.

Although the quality of the systems was better than expected, Nippon Columbia was not satisfied. This is why it has undertaken in the past few years experiments to improve the dynamic range, enhance the quality of duplicating, achieve synchronized recording and the systems easier to handle.

In 1977, Nippon Columbia unwrapped a new improved PCM recording system, the DN-034R.

The Improved DENON PCM Recording System (DN-034R)

The DN-034R is capable of eight-channel recording and reproduction.

It is an improved version of the system (DN-023R) described in the Journal of AES published in September 1973 (volume 21, 7). Both systems are compatible and a four-head low-hand video tape recorder is used as the mechanical part of the recording system.

The new system features an emphasis circuit and 14-bit A/D and D/A conversions are introduced to improve the dynamic range, while selection circuit for the digital data is adopted for improved duplicating and synchronized recording, using two video tape recorders and one converter.

As shown in Fig. 2, the system digitizes eight audio signals and records PCM transmission waveforms (Fig. 3) recorded as FM on the tape with the VTR.

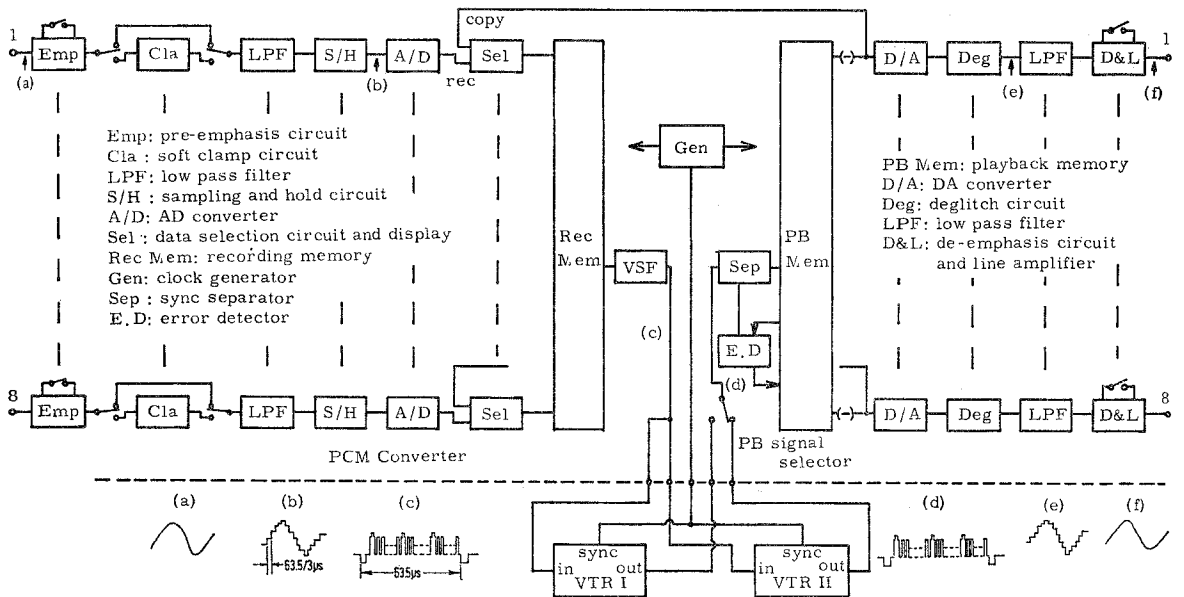

Fig. 2 Block diagram

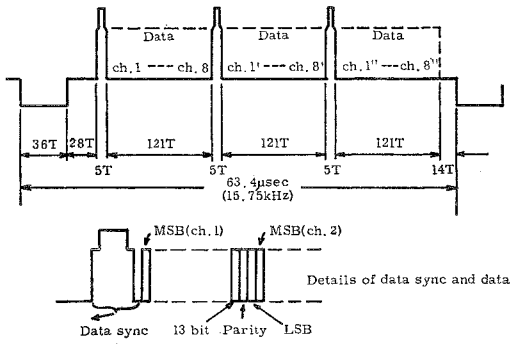

Fig. 3 Transmission waveforms

For reproduction, the recorded signal is demodulated first, data are extracted by the clock signal and stored in a shift register.

Data errors are then detected and corrected, whereupon the data are converted into the recorded audio signals.

In the practical recording process, the input and output of the recording system are connected to the mixing console, monitor system and disc cutting system. An emphasis circuit is adopted to improve the system's dynamic range. The emphasis curve employed is shown in Fig. 4.

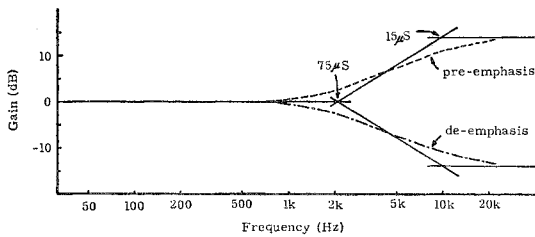

Fig. 4 Emphasis curves

In addition a soft clamp circuit which has saturation characteristics resembling those of an ordinary tape, is also featured. But the signals bypass this circuit except when special effects are required.

There are three duplication methods; audio signal, transmission signal, and data duplication. With the first method, quantizing noise increases and with the second data errors multiply because of the noise and jitter in the transmission signal. The best method is therefore data duplication which is achieved in this system to select the data.

Synchronized recording is also possible using two VTRs and the data selection circuit.

The system's frequency response and distortion characteristics are shown Fig. 5 and 6.

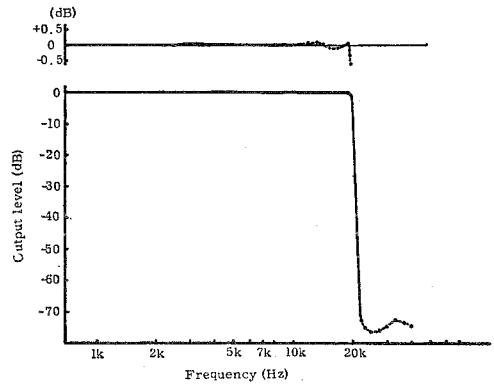

Fig. 5 Frequency response

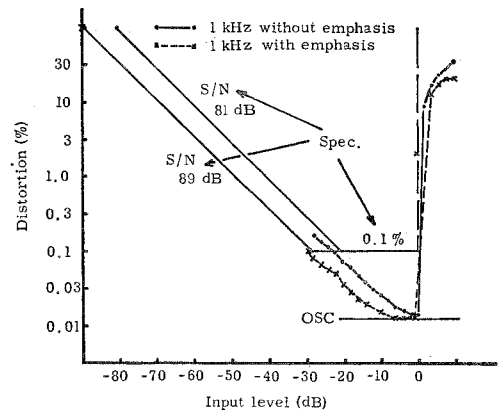

Fig. 6 Distortion characteristics

Applications

The improved DENON PCM recording system (DN-034R) is so superior to conventional recorders in its dynamic range, frequency response, distortion factor and quality of duplication that it can be used not only as a studio or disc cutting recorder, but also as a standard sound generator for developing or testing sound equipment and as a data recorder for recording and analyzing vibration, noise, music and other signals and the characteristics of sound equipment.

This system also has input and output connectors for digital data.

Therefore, a very wide-ranging variety of purposes can be served by combining the system with a digital mixing console and a computer.

DENON PCM Recording System (DN-034R)

Specifications

Modulation; pulse-code modulation.
Coding; 14-bit sign and magnitude binary code.
Transmission clock frequency; 7.1825 MHz.
Audio sampling frequency; 47.25 kHz.
Transmission waveform; standard TV signal (except vertical sync signal).
Number of audio channels; 8/4/2 selectable.
Tape speed; 38.1 cm/s.
Usable tape; 2-inch video tape.

Electrical performance

Frequency response: DC—19 kHz ± 0.2 dB, DC—20 kHz $+0.2$ dB—1.0 dB
Dynamic range: more than 81 dB (without emphasis)
more than 89 dB (with emphasis)
Distortion: less than 0.1% (at operating level)
Interchannel crosstalk: less than -80 dB
Wow and flutter: not measurable

Configuration of DN-034R

PCM converter, dimensions; 760(W) x 400(H) x 570(D)mm, weight; 62 kg.
Magnetic tape recorder (four-head low-band VTR), dimensions; 760(W) x 480(H) x 550(D)mm, weight; 100 kg.
Audio monitor, dimensions; 500(W) x 110(H) x 310(D)mm, weight; 8 kg.
Video & waveform monitor, dimensions; 500(W) x 155(H) x 360(D)mm, weight; 12 kg.

**In 1979, we developed new PCM (digital) Recording Equipment DENON DN-035R.
The outlines below :-**

(Specifications)

Modulation: pulse code modulation
Coding: 16-bit 2's complement code
Transmission clock frequency: 3.0713 MHz
Audio sampling frequency: 47.25 kHz (44—54 kHz selectable)
Transmission waveform: standard TV signal
Number of audio channels: 4/2 selectable
Usable tape transport: U-matic VTR/4-head-type VTR

(Electrical performance)

Frequency response: dc—20 kHz ± 0.5 dB
Dynamic range: more than 93 dB (without emphasis)
more than 98 dB (with emphasis)
Distortion: less than 0.03%
Interchannel crosstalk: less than -90 dB
Wow and flutter: not measurable



NUMERICAL LIST FOR INVENTORY AND ORDER

RECORD No.	INV	ORD	INV	ORD	INV	ORD	INV	ORD	RECORD No.	INV	ORD	INV	ORD	INV	ORD
• CLASSICAL									0X-7031						
0X-7002									0X-7032						
0X-7004									0X-7033						
0X-7005									0X-7034						
0X-7006									0X-7035**						
0X-7007*									0X-7036						
0X-7008									0X-7037** 7038						
0X-7009									0X-7039						
0X-7011									0X-7040						
0X-7012									0X-7041						
0X-7013									0X-7042						
0X-7014									0X-7043**						
0X-7021***									0X-7044						
0X-7022*									7045 0X- 7 7047						
0X-7023									0X-7048						
0X-7024									0X-7049**						
0X-7025*									0X-7051*						
0X-7026									0X-7052*						
0X-7027									0X-7053*						
0X-7028									0X-7054*						
0X-7029									0X-7055*						
0X-7030									0X-7056*						

RECORD No.	INV	ORD	INV	ORD	INV	ORD	INV	ORD	RECORD No.	INV	ORD	INV	ORD	INV	ORD	INV	ORD
0X-7057*									0X-7081								
0X-7058*									0X-7082								
0X-7059									0X-7083								
0X-7060									0X-7084								
0X-7061									0X-7085								
0X-7063									0X-7086								
0X-7064									7087								
0X-7065									0X-7088								
0X-7066**									0X-7089**								
0X-7067**									0X-7090								
0X-7068									0X-7091								
0X-7069									0X-7092								
0X-7070									0X-7093								
0X-7071									0X-7094								
0X-7072									0X-7095								
0X-7073									0X-7096								
0X-7074									0X-7097								
0X-7075									0X-7098								
0X-7076									0X-7099								
0X-7077**									0X-7100								
0X-7078									0X-7101								
0X-7079									0X-7102								
0X-7080									0X-7103								

RECORD No.	INV	ORD	INV	ORD	INV	ORD	INV	ORD	RECORD No.	INV	ORD	INV	ORD	INV	ORD	INV	ORD
0X-7104									0X-7128								
0X-7105**									0X-7129								
0X-7106									0X-7130								
0X-7107 7108									0X-7131**								
0X-7109									0X-7132								
0X-7110**									0X-7133								
0X-7111									0X-7134**								
0X-7112									0X-7135								
0X-7113									0X-7136								
0X-7114**									0X-7137								
0X-7116									0X-7138**								
0X-7117									0X-7139**								
0X-7118									0X-7140								
0X-7119									0X-7141**								
0X-7120									0X-7142								
0X-7121									0X-7143								
0X-7122**									0X-7144								
0X-7123									0X-7145								
0X-7124									0X-7146								
0X-7125									0X-7147								
0X-7126									0X-7149								
0X-7127									0X-7150								

RECORD No.	INVORD	INVORD	INVORD	INVORD	RECORD No.	INVORD	INVORD	INVORD	INVORD
OX-7151					OX-7175				
OX-7152					OX-7176				
OX-7153					OX-7177				
OX-7154					OX-7178**				
OX-7155					OX-7179				
OX-7156					OX-7180				
OX-7157					OX-7181				
OX-7158					OX-7182				
OX-7159 OX-7160					OX-7183				
OX-7161					OX-7184				
OX-7162					OX-7185				
OX-7163					OX-7186				
OX-7164					OX-7187				
OX-7165					OX-7188				
OX-7166 OX-7167					OX-7189				
OX-7168					OX-7190				
OX-7169					OX-7191				
OX-7170					OX-7192**				
OX-7171					OX-7193 OX-7194 OX-7195				
OX-7172					OX-7196				
OX-7173					OX-7197				
OX-7174					OX-7198*				

RECORD No.	INV	ORD	INV	ORD	INV	ORD	INV	ORD	INV	ORD	RECORD No.	INV	ORD	INV	ORD	INV	ORD	INV	ORD	
OX-7199											YX-7503									
OX-7200*											YX-7504									
OX-7201***											YX-7505									
OX-7202											YX-7506									
											YX-7507									
											YX-7511									
											YX-7512									
											YX-7513									
OB-7333 7334											YX-7514									
OB-7335 7336											YX-7515									
OB-7337 7338**											YX-7516									
OB-7339 7340											YX-7517									
OB-7346 7347											YX-7518									
OB-7348 7349											YX-7519									
OB-7350 7351											YX-7520									
											YX-7521									
7214 OQ- 7 * 7221											YX-7522									
7440 OQ- 7 ** 7442											YX-7523									
7443 OQ- 7 ** 7445											YX-7524									
• JAZZ										YX-7525										
YX-7501											YX-7526									
YX-7502											YX-7527									

RECORD No.	INV	ORD	INV	ORD	INV	ORD	INV	ORD	RECORD No.	INV	ORD	INV	ORD	INV	ORD	INV	ORD			
YX-7528									YX-7802											
YX-7530									YX-7803											
YX-7531									YX-7804											
YX-7532									YX-7805											
YX-7533									YX-7806											
YX-7534									YX-7807											
YX-7535																				
YX-7536									• POPULAR											
YX-7537									YX-7262											
YX-7538									YX-7277											
YX-7539																				
YX-7540									SX-7001											
YX-7541									SX-7002											
YX-7543									SX-7003											
YX-7544									SX-7004											
YX-7545									SX-7005											
YX-7546									SX-7006											
YX-7547									SX-7007											
YX-7548									SX-7008											
YX-7549									SX-7009											
YX-7550									SX-7010											
YX-7801									SX-7011											

RECORD No.	INV	ORD	INV	ORD	INV	ORD	INV	ORD	RECORD No.	INV	ORD	INV	ORD	INV	ORD	INV	ORD
• JAPANESE TRADITIONAL																	
WP-7005									WX-7518								
WP-7006									WX-7519								
WP-7007									WX-7520								
WP-7008									• OTHERS								
WP-7009									ZX-7018								
WX-7501									ZX-7019								
WX-7502									ZX-7020								
WX-7503									GX-7027								
WX-7506									GX-7108								
WX-7507									• SPECIAL ISSUED ALBUM								
WX-7508									ST-6007								
WX-7509									ST-6008								
WX-7510									ST-6011								
WX-7511									• AUDID TECHNICAL TEST RECORD								
WX-7512									OW-7403								
WX-7513									OW-7404								
WX-7514									XG-7002								
WX-7515									XG-7003								
WX-7516									XG-7004								
WX-7517									XG-7005								

ST-6011	<p>INVITATION TO DENON/PCM DIGITAL CLASSICS PART 2</p> <p>*Symphony No. 5 "EROICA"—1st Movement (Beethoven) SUITNER conducting STAATSKAPELLE BERLIN (from OX-7202)</p> <p>*Concerto for Flute and Harp KV299—1st Movement (Mozart) ADORJAN, MILDONIAN, STADIMAIR conducting MUNCHENER KAMMERORCHESTER (from OX-7181)</p> <p>*Divertiment for Oboe, Viola and Contrabass—1st Movement (Haydn) HOLLIGER, PARIS, BUCCARELLA</p> <p>*Symphony No. 6 "PATHETIQUE"—3rd Movement (Tchaikovsky) SANDERING conducting BERLIN SYMPHONY ORCHESTRA (from OX-7183)</p> <p>*Concerto for Piano and Strings BWV 1052—1st Movement (J. S. Bach) SCHIFF, MALCOM conducting ENGLISH CHAMBER ORCHESTRA (from OX-7182)</p> <p>*Holberg Suite for String Orchestra—Rigauden (Greig) BAROQUE STRING ZURICH (from OX-7120)</p> <p>*Concerto for Violin and Strings "FOUR SEASONS"—"Spring" (Vivaldi) LARSENS, BAUMGARTNER conducting FESTIVAL STRINGS LUCERN (from OX-7174)</p> <p>*Tocatta and Fugue BWV 565 (J. S. Bach) HANS OTTO (from OX-7184)</p> <p>*Wind Quintet Op.88, No. 2—Finale (Reicha) TAFFANEL WIND QUINTET (from OX-7161)</p> <p>*Symphony No. 2, Op.45—4th Movement (Sibelius) ATZMON conducting THE TOKYO METROPOLITAN SYMPHONY ORCHESTRA</p> <p>*Concerto No. 2 for Violin and Strings BWV 1042—1st Movement (J. S. Bach) KANTOROW, STADLMAIR conducting MUNCHENER KAMMERORCHESTER (from OX-7196)</p> <p>*Liebesfreude (Kreisler—Rachmaninoff) JEFFREY SIEGEL (from OX-7189)</p>
---------	--